

MULA Series

High Efficiency Step-UP LED Driver



Features

- RoHS-compliant 2"x1" case Package Power LED Driver
- Constant Current Output (±5% Output Current Accuracy)
- LED Driver Current 150 / 250 / 300 / 350 / 500 / 600 / 700 / 900 mA
- Power LED Driver
- Wide Input Voltage Range: 9V to 36V (38V for 0.1sec)
- Output Power 7.2 / 12 / 14.4 / 16.8 / 24 / 28.8 / 33.6 / 43.2 W
- Driver LED Strings of up to 48V (14V to 48V)
- High Efficiency (up to 95%)
- PWM/Digital Dimming and Analog Voltage Dimming
- Open and Short LED Protection
- Pin or Wire Versions
- -40°C ~ 85°C Operation Temperature Range
- IP67 rated for Wired Version
- With MLCC Capacitors only

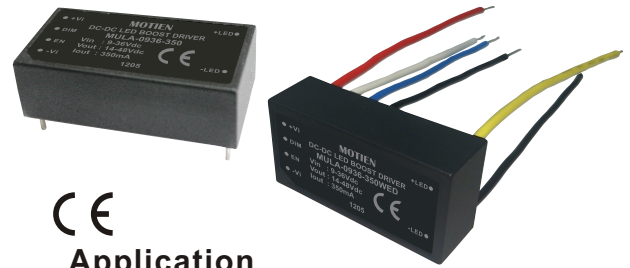

Application

- 12V / 24V Solar Lighting Systems
- Household/Commercial lighting
- Suitable for high illumination LED
- Power limited (battery) lighting system

MULA series is a high efficiency step-up converter optimized to drive high current LEDs. The control algorithm allows highly efficient and accurate LED current regulation. The device operates from an input 9Vdc to 36Vdc and provides an externally adjustable output current up to 900mA and output power up to 43.2 watts. Compact size of 2"x1" case allows designer to integrate this driver together with LED module. UL94V-0 grade molded case with high grade filling material provide excellent fire proof characteristics.

Typical at Ta = +25°C, nominal input voltage, maximum output voltage unless otherwise specified.

Electrical Specifications		
Input Voltage (Vdc)	(Io=100mA~700mA) (Io=900mA)	9V ~ 36V, 24V Nominal 20V ~ 30V, 24V Nominal
Input Filter		Capacitor
Output Voltage Range (Vo - Vin ≥ 5V) (1)	(Io=100mA~700mA) (Io=900mA)	14V to 48V 25V to 48V
Output Current Range (Vo - Vin ≥ 5V)		See table
Output Current Accuracy		±5%, max.
Output Power (2)		See table, max.
Ripple and Noise (20 MHz bandwidth)		See table, max.
Efficiency		See table, typ.
Capacitive Load (3)		See table, max.
Operating Frequency		370KHz, typ.
Over Voltage Protection (OVP)		52.5V, max.
Short Circuit Protection (4)		Automatic Recovery(Cut-off output)
Under Voltage Lockout (Cool Start) (5)		
	Module ON / OFF (Io=100mA~700mA)	7.6Vdc / 6.8Vdc, typ.
	Module ON / OFF (Io=900mA)	15.6Vdc / 14.6Vdc, typ.
Soft Start Time (Not to increase additional output capacitor)		50mS, max.
Temperature Coefficient (Ta = -40°C to +85°C)		±0.03%/°C, max.
Thermal Impedance (Nature Convection)		+17°C/W
Safety Standard(designed to meet)		IEC/EN 60950-1 UL8750 and IEC/EN61347-2-13

Environmental Specifications	
Operating Temperature Range, Ta	-40°C to +85°C(See Derating Curve)
Storage Temperature Range	-55°C to +125°C
Humidity	95% rel H
Water Resistance (Wired Version only)	IP67
Maximum Case Temperature	+105°C
Cooling	Nature Convection
Reliability Calculated MTBF(MIL-HDBK-217 F)	>838Khrs
Soldering Temperature (1.5mm from case 10sec max.)	+260°C, max.

ON/OFF Control (Leave Open if Not Used): (EN)	
DC/DC ON	Open
DC/DC OFF (Shutdown)	0V
Remote Pin Drive Current (VEN ≤ 3V)	<1.5μA
Quiescent Input Current in Shutdown Mode (Vin 9V~32V)	1.3mA, max.
	(Vin 32V~36V) 8mA, max.

Analog and PWM Dimming Control (Leave Open if Not Used): (DIM)	
Absolute Maximum Ratings	0V to 5V(8V for 0.1sec)
Analog Dimming Control	
DIM Input Voltage Range (See Output Current Vs DIM Graph)	
ON	0.4V to 1.7V
Adjust Output Current (0.4V to 1.7V)	0% to 100%
Adjust Output Current (1.7V to 5V)	100%
OFF	0V to 0.3V
DIM Pin Drive Current (0.4V ≤ VDIM ≤ 1.7V)	<1.5μA
PWM Dimming Control (6)	
PWM Control Voltage Range Limits (See Output Current Vs DIM Graph)	
ON	0.4V to 5.0V
OFF	0V to 0.3V
Recommended Operation Frequency	100Hz~100KHz
Adjust Output Current	0% to 100%

Physical Specifications	
Case Material	Non-conductive Black Plastic(UL94V-0 rated)
Potting Material	Epoxy (UL94V-0 rated)
Pin Material	Φ1.0mm Brass Solder-coated
Lead Wires	UL 1015/CSA TEM listed/ 18AWG / 600V/ 105°C Rated UL 1015/CSA TEM listed/ 22AWG / 600V/ 105°C Rated
Weight (Pinned / Wired)	38.0g / 44.2g
Dimensions	2.03"(L)x1.03"(W)x0.62"(H)

EMC Specifications	
EMI Radiated & Conducted Emissions	EN 55015 (CISPR22)
EMS Immunity EN 61547	
IEC 61000-4-2	Perf. Criteria A
IEC 61000-4-3	Perf. Criteria A
IEC 61000-4-4	Perf. Criteria A
IEC 61000-4-5	Perf. Criteria A
IEC 61000-4-6	Perf. Criteria A
IEC 61000-4-8	Perf. Criteria A

The information and specifications contained in this data sheet are believed to be correct at time of publication. However, MOTIEN Technologies accepts no responsibility for consequences arising from printing errors or inaccuracies. Specifications are subject to change without notice. No rights under any patent accompany the sale of any such product(s) or information contained herein.

PART NUMBER STRUCTURE

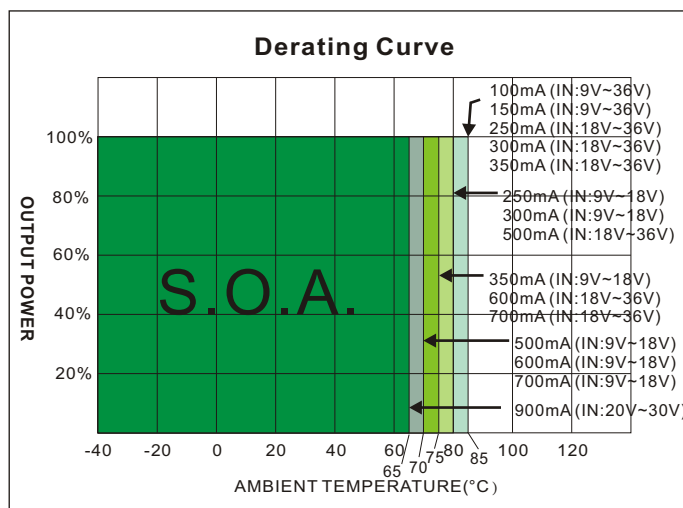
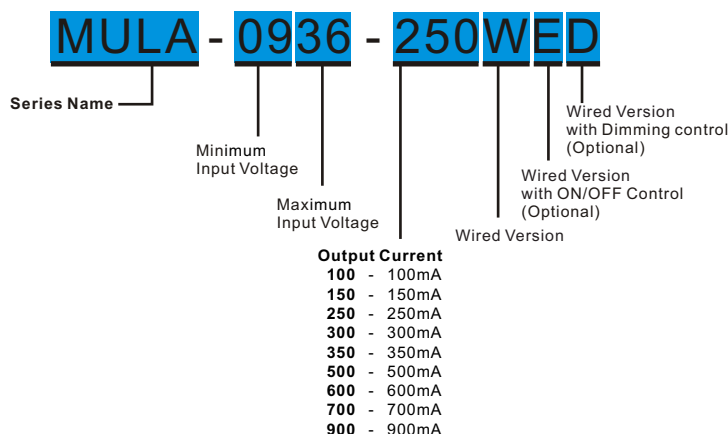

MODEL SELECTION GUIDE

MODEL NUMBER	INPUT	OUTPUT		OUTPUT Current	OUTPUT	EFFICIENCY	Capacitor Load @FL	
	Voltage Range (Vdc)	Voltage Range (Vdc)	Current (mA)	Accuracy (% , max.)	Power (W, max.)	@FL (% , typ.)		Ripple and Noise (mVp-p, max.)
MULA-0936-100	9 - 36	14 - 48	100	±5	4.8	83 - 88	250	47
MULA-0936-150	9 - 36	14 - 48	150	±5	7.2	86 - 91	350	100
MULA-0936-250	9 - 36	14 - 48	250	±5	12.0	89 - 93	450	100
MULA-0936-300	9 - 36	14 - 48	300	±5	14.4	89 - 94	450	100
MULA-0936-350	9 - 36	14 - 48	350	±5	16.8	89.5 - 94	600	100
MULA-0936-500	9 - 18	14 - 45	500	±5	24.0	90 - 95	650	47
	18 - 36	23 - 48						
MULA-0936-600	9 - 18	14 - 38	600	±5	28.8	91 - 95	650	47
	18 - 36	23 - 48						
MULA-0936-700	9 - 18	14 - 32	700	±5	33.6	91.5 - 95	700	47
	18 - 36	23 - 48						
MULA-2030-900	20 - 30	25 - 48	900	±5	43.2	92 - 95	400	47
MULA-0936-100WED	9 - 36	14 - 48	100	±5	4.8	83 - 88	250	47
MULA-0936-150WED	9 - 36	14 - 48	150	±5	7.2	86 - 91	350	100
MULA-0936-250WED	9 - 36	14 - 48	250	±5	12.0	89 - 93	450	100
MULA-0936-300WED	9 - 36	14 - 48	300	±5	14.4	89 - 94	450	100
MULA-0936-350WED	9 - 36	14 - 48	350	±5	16.8	89.5 - 94	600	100
MULA-0936-500WED	9 - 18	14 - 45	500	±5	24.0	90 - 95	650	47
	18 - 36	23 - 48						
MULA-0936-600WED	9 - 18	14 - 38	600	±5	28.8	91 - 95	650	47
	18 - 36	23 - 48						
MULA-0936-700WED	9 - 18	14 - 32	700	±5	33.6	91.5 - 95	700	47
	18 - 36	23 - 48						
MULA-2030-900WED	20 - 30	25 - 48	900	±5	43.2	92 - 95	400	47

The information and specifications contained in this data sheet are believed to be correct at time of publication. However, MOTIEN Technologies accepts no responsibility for consequences arising from printing errors or inaccuracies. Specifications are subject to change without notice. No rights under any patent accompany the sale of any such product(s) or information contained herein.

MECHANICAL DIMENSION

Pinned Version

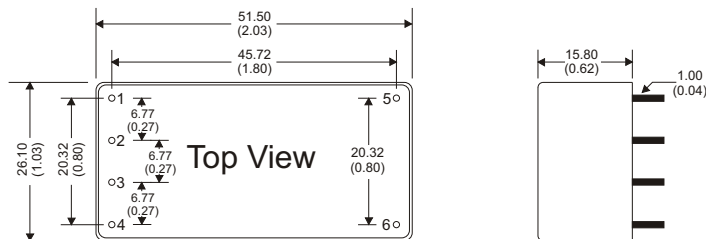

PIN CONNECTIONS		
PIN #	CONNECTIONS	
1	+Vi	+DC Supply
2	DIM	PWM/ Analog Dimming Control
3	EN	Remote ON/OFF
4	-Vi	-DC Supply (GND)
5	+ LED	LED Anode Connection
6	- LED	LED Cathode Connection

All dimensions are typical in millimeters (inches)
 1. Pin diameter: 1.0 ±0.05 (0.04 ±0.002)
 2. Pin pitch and length tolerance: ±0.35 (±0.014)
 3. Case Tolerance: ±0.5 (±0.02)

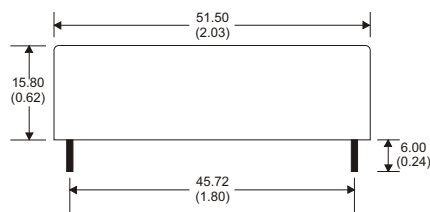

Wired Version

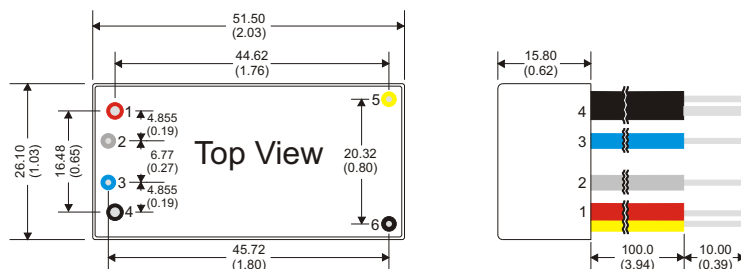

CONNECTIONS		
Wires #	CONNECTIONS	
1 (Red)	+Vi	+DC Supply
2 (White)	DIM	PWM/ Analog Dimming Control
3 (Blue)	EN	Remote ON/OFF
4 (Black)	-Vi	-DC Supply (GND)
5 (Yellow)	+ LED	LED Anode Connection
6 (Black)	- LED	LED Cathode Connection

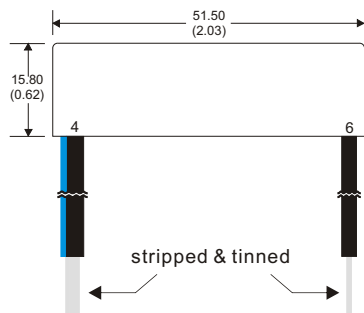

Notes : All dimensions are typical in millimeters (inches).
 1. Wire core diameter: 0.80±0.1 (0.031±0.004) & 1.40±0.1 (0.055±0.004)
 2. Wire outside diameter: 2.4±0.1 (0.094±0.004) & 2.7±0.1 (0.106±0.004)
 3. Wire length = 100 + 10 stripped & tinned = 110±5 (4.33±0.197) total
 4. Case Tolerance: ±0.50 (±0.02)

NOTE

1. To prevent the burned out of driver, The output voltage must be 5.0Vdc higher than input voltage.
2. DO NOT operate the driver over output power.
3. The Output ripple has been rather low, it's recommended not to increase the additional output capacitor, otherwise there will be time delay while starting up under cool starting.
4. There is protection while output is shorted, after the short occurs , input current will be cut off and recover while short is removed.
5. The reference value of under voltage protection -- 7.6V means under the condition of cool start and full discharge of output, protection starts when input voltage is lower under 7.6V.
6. Please note , PWM dimming means PWM signals is converted into mimic analog voltage by internal circuits and then do the dimming. The advantage of such approach is to reduce the EMI.

The information and specifications contained in this data sheet are believed to be correct at time of publication. However, MOTIEN Technologies accepts no responsibility for consequences arising from printing errors or inaccuracies. Specifications are subject to change without notice. No rights under any patent accompany the sale of any such product(s) or information contained herein.

Typical electrical characteristic curves

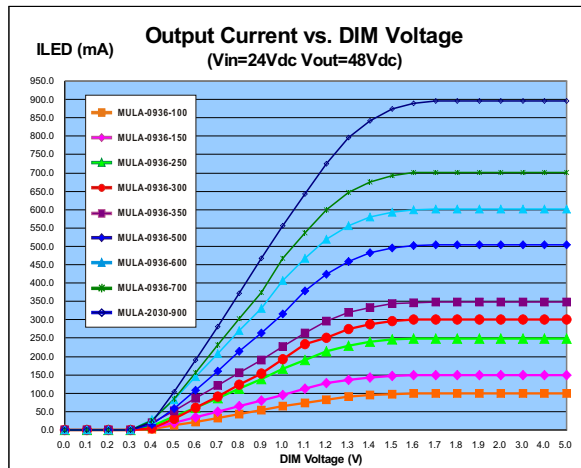

MULA-0936-100

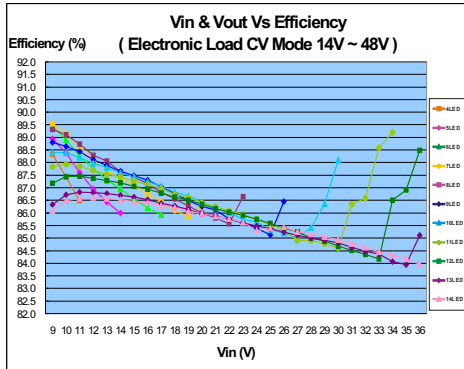

MULA-0936-150

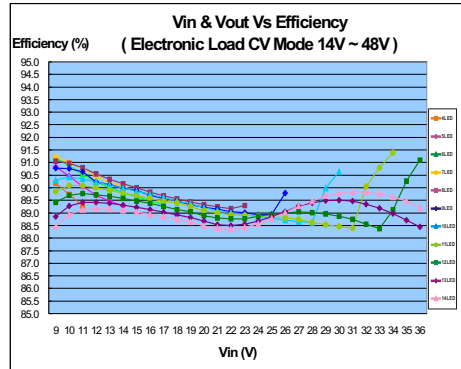

MULA-0936-250

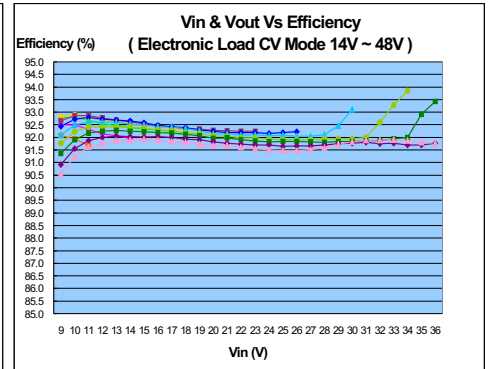

MULA-0936-300

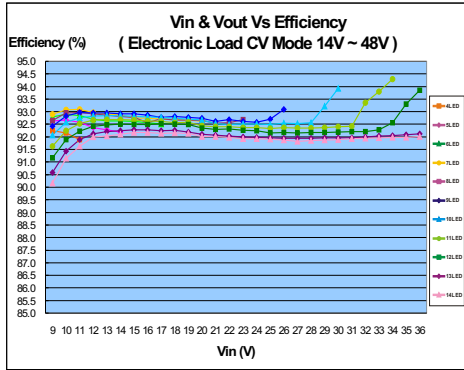

MULA-0936-350

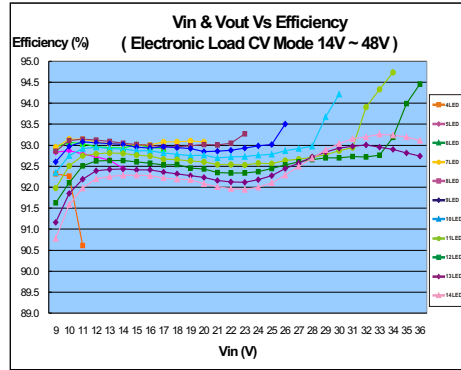

MULA-0936-500

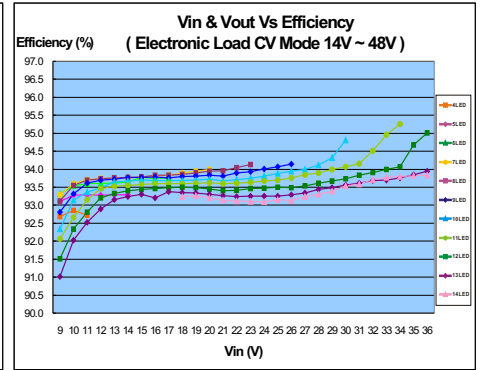

MULA-0936-600

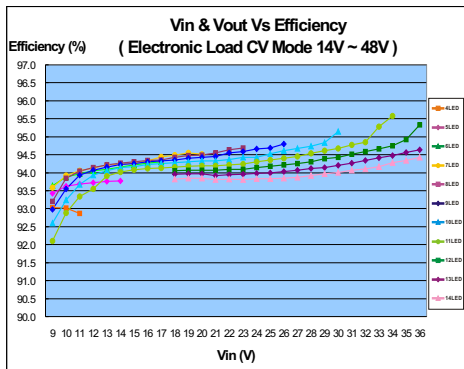

MULA-0936-700

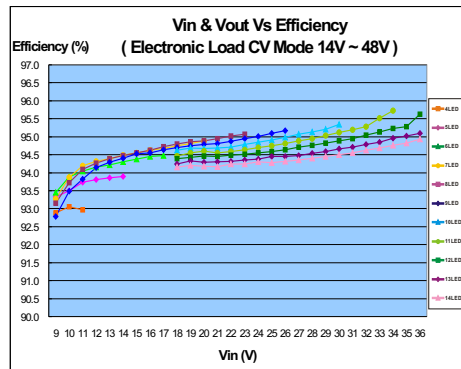

MULA-2030-900

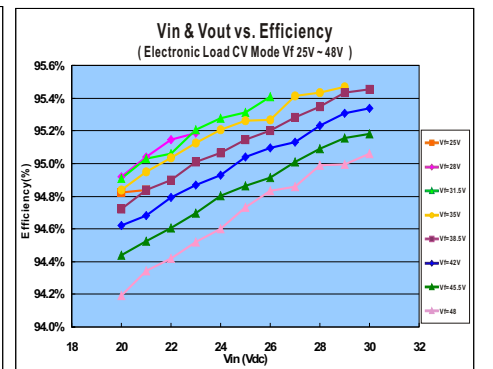

The information and specifications contained in this data sheet are believed to be correct at time of publication. However, MOTIEN Technologies accepts no responsibility for consequences arising from printing errors or inaccuracies. Specifications are subject to change without notice. No rights under any patent accompany the sale of any such product(s) or information contained herein.

EMC Characteristics

EMC Countermeasures Suggestion

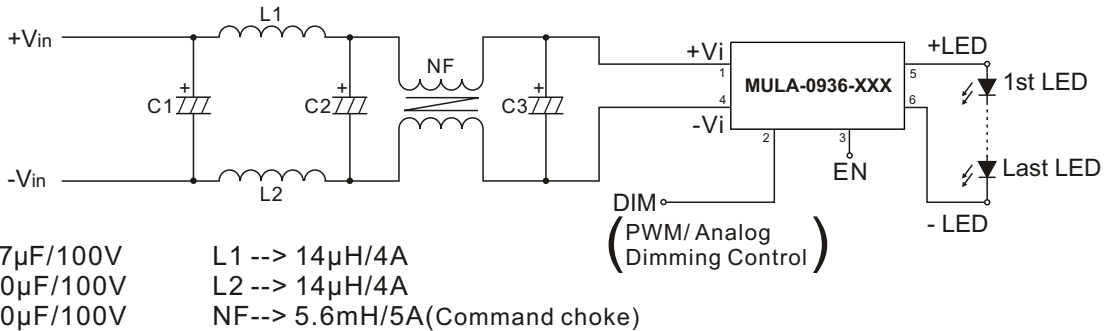

Conducted Emissions Test

Vin=24V Vout=48V(LED Load Vf=3.5V · 14LED=48V)
POLARITY:NEUTRAL

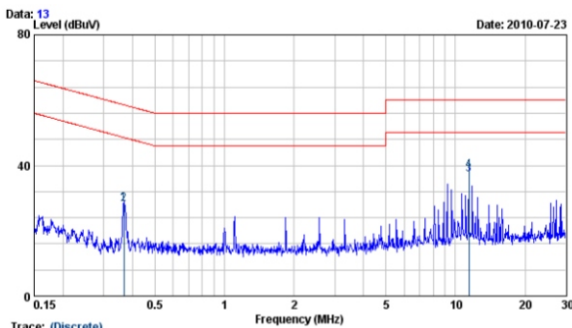

Freq. MHz	LISN Factor dB	Cable Loss dB	Meter Reading dBuV	Measured Level dBuV	Limits dBuV	Over Limits dBuV	Detector
0.367	9.81	0.02	18.39	28.22	58.56	-30.35	QP
0.367	9.81	0.02	18.34	28.17	48.56	-20.40	AVERAGE
11.405	110.30	0.13	26.75	37.16	50.00	-12.84	AVERAGE
11.405	110.30	0.13	27.92	38.35	60.00	-21.65	QP

REMARKS: 1.Level(dBuV)=Read Level(dBuV)+LISN Factor(dB)+Cable loss(dB)
2.Over Limit value(dB)=Level(dBuV)-Limit Line(dBuV)

Vin=24V Vout=48V(LED Load Vf=3.5V · 14LED=48V)
POLARITY:LINE

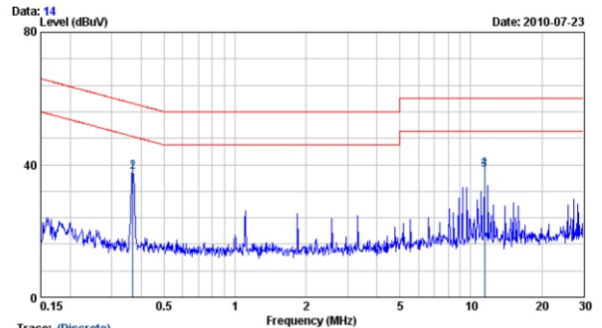

Freq. MHz	LISN Factor dB	Cable Loss dB	Meter Reading dBuV	Measured Level dBuV	Limits dBuV	Over Limits dBuV	Detector
0.369	9.82	0.02	27.72	37.56	58.52	-20.96	QP
0.369	9.82	0.02	28.11	37.95	48.52	-10.57	AVERAGE
11.409	110.35	0.13	27.87	38.35	50.00	-11.65	AVERAGE
11.409	110.35	0.13	28.32	38.80	60.00	-21.20	QP

REMARKS: 1.Level(dBuV)=Read Level(dBuV)+LISN Factor(dB)+Cable loss(dB)
2.Over Limit value(dB)=Level(dBuV)-Limit Line(dBuV)

Radiation Emissions Test Result

Vin=12V Vout=32V(LED Load Vf=3.5V · 9LED=32V)
POLARITY:HORIZONTAL

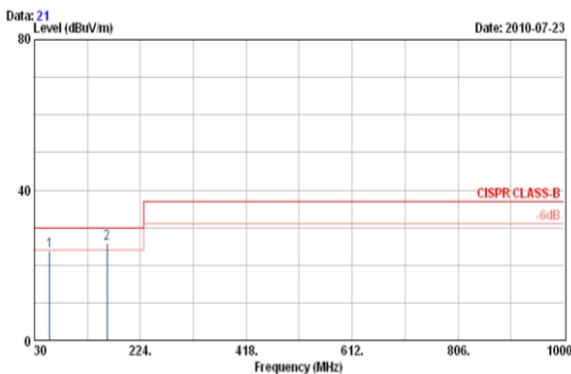

Freq. MHz	Reading Level dBuV	Antenna Factor dB/m	Cable Loss dB	Measure Level dBuV/m	Limit dBuV/m	Over Limit dBuV/m	Detector
57.50	14.48	7.88	1.41	23.77	30.00	-6.23	QP
162.88	10.46	12.21	3.03	25.70	30.00	-4.30	QP

Vin=24V Vout=48V(LED Load Vf=3.5V · 14LED=48V)
POLARITY:HORIZONTAL

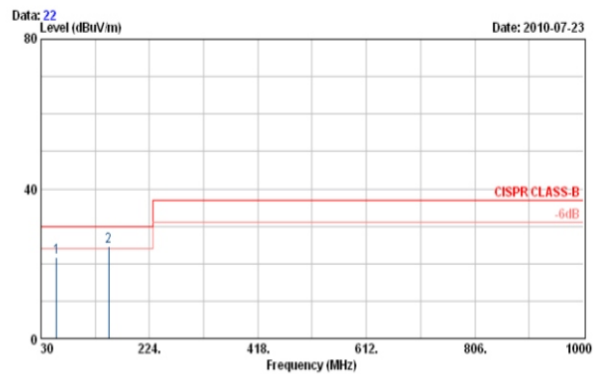

Freq. MHz	Reading Level dBuV	Antenna Factor dB/m	Cable Loss dB	Measure Level dBuV/m	Limit dBuV/m	Over Limit dBuV/m	Detector
57.83	12.47	7.82	1.44	21.73	30.00	-8.27	QP
150.90	9.12	12.74	2.87	24.73	30.00	-5.27	QP

Typical Application

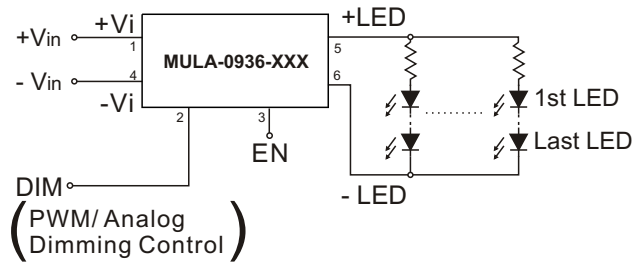
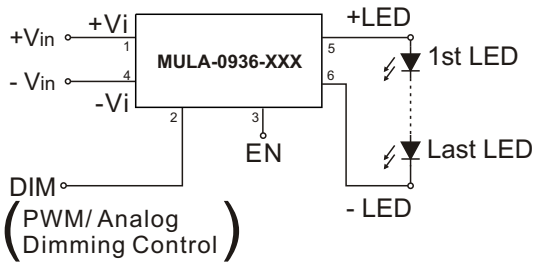
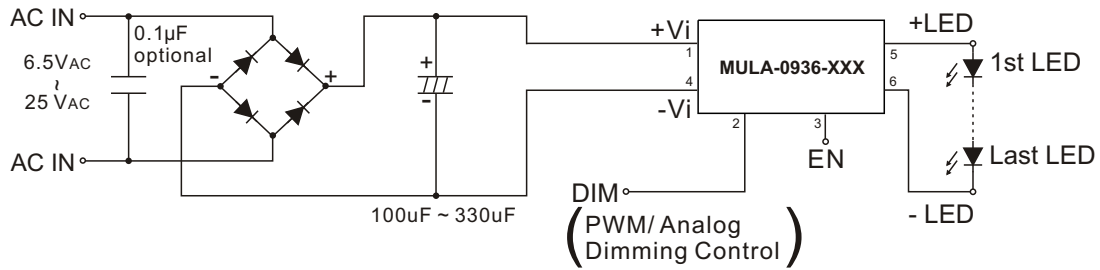

Under Voltage Protection

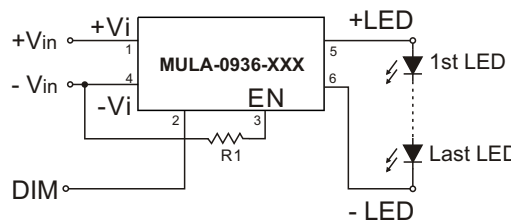
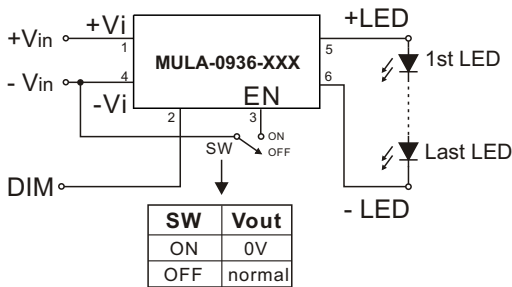

The R1 Value Only Supplies The Reference

Output Current Adjustment Control By External DC Control Voltage

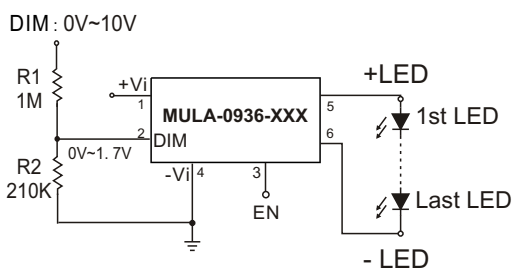
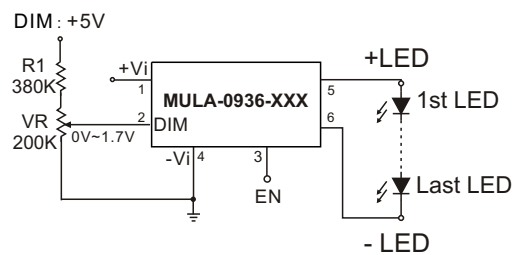
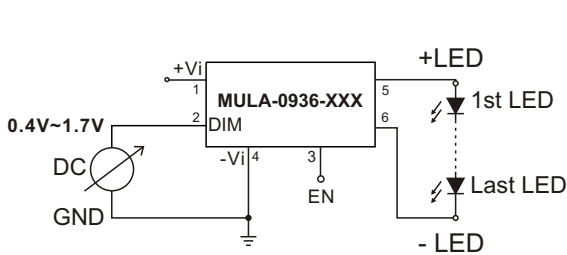

Vin	R1
5V	4.7K
12V	18K
24V	43K
36V	62K

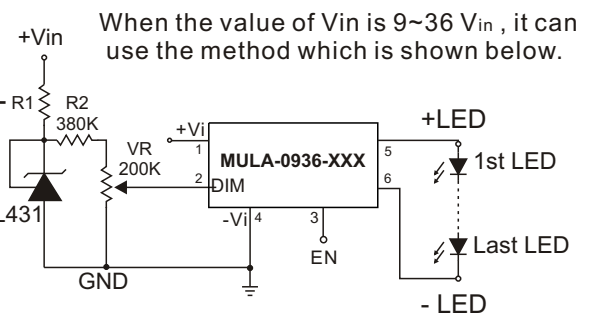

When the value of Vin is 9~36 Vin, it can use the method which is shown below.

The information and specifications contained in this data sheet are believed to be correct at time of publication. However, MOTIEN Technologies accepts no responsibility for consequences arising from printing errors or inaccuracies. Specifications are subject to change without notice. No rights under any patent accompany the sale of any such product(s) or information contained herein.

Typical Application

Output Current Adjustment Control By PWM Control

Directly driving DIM input

A Pulse Width Modulated (PWM) signal can be applied to the DIM pin, as shown below

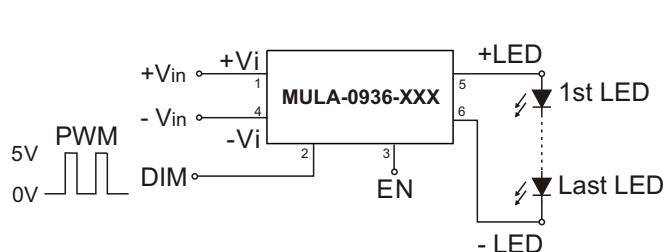

Driving the DIM input via open collector transistor

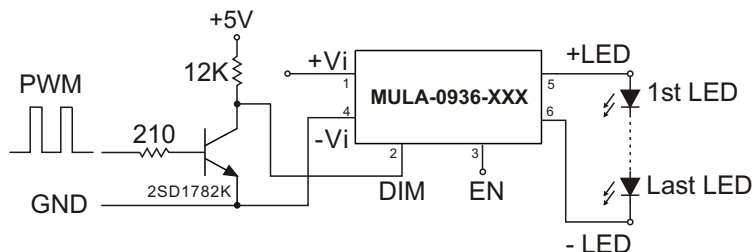

Driving the DIM input from a microcontroller

Another possibility is to drive the device from the open drain output of a microcontroller. The diagram below shows one method of doing this:

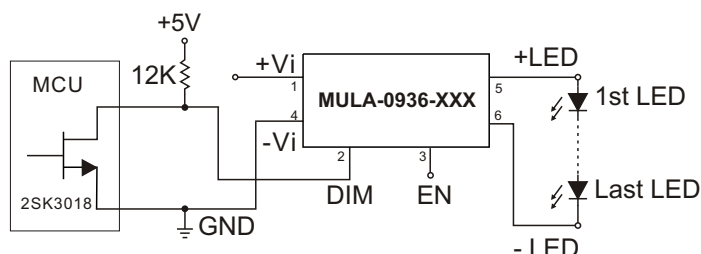

Output Current Adjustment By PWM Control (Dimming)

To avoid visible flicker the PWM signal must be greater than 100Hz.

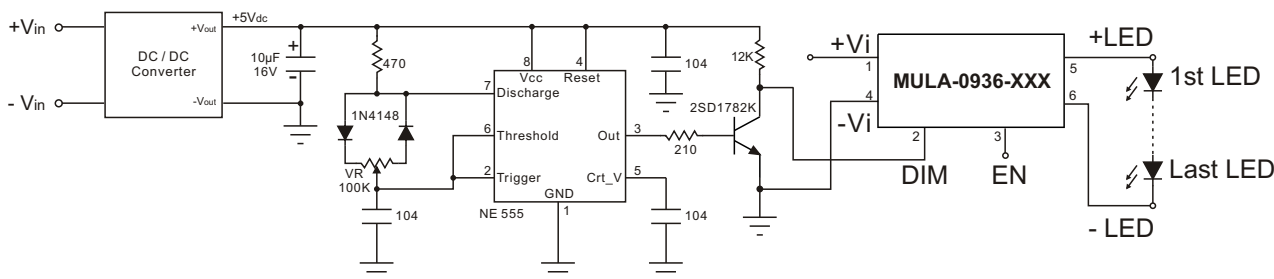

Output Current Adjustment By PWM Control (Flash)

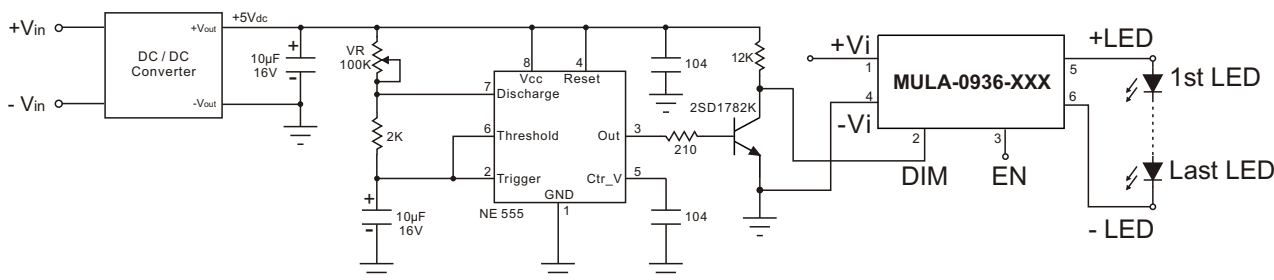

The information and specifications contained in this data sheet are believed to be correct at time of publication. However, MOTIEN Technologies accepts no responsibility for consequences arising from printing errors or inaccuracies. Specifications are subject to change without notice. No rights under any patent accompany the sale of any such product(s) or information contained herein.