

# V7 - 15W Series



15W 2:1 Regulated Single & Dual output

## Features

- Wide 2:1 Input Range
- Full SMD Technology
- 1500~3500 VDC Isolation
- Continuous Short Circuit Protection
- Efficiency up to 87%
- -40 ~ 85°C Operation Temperature Range
- EMI Complies With EN55022 Class A
- CB & UL Certified Available For 1500VDC Isolation Models

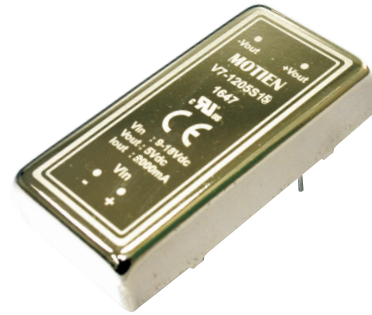

The V7 series is a family of cost effective 15W single & dual output DC-DC converters. These converters are made with nickle-coated brass case in a 2"x1" with high performance features such as 1500 VDC input/output isolation voltage, continuous short circuit protection with automatic restart and tight line / load regulation. Devices are encapsulated by using flame retardant resin. Input voltages of 12,24 and 48 with output voltage of 3.3,5,7.2,9,12,15,18,24,±3.3,±5,±7.2,±9,±12,±15,±18,±24 Vdc. High performance features include high efficiency operation up to 87% and output voltage accuracy of ±1% maximum.

All specifications typical at Ta=25°C, nominal input voltage and full load unless otherwise specified

OUTPUT SPECIFICATIONS	
Voltage accuracy	±1%, max.
Line regulation	±0.5%, max.
Load regulation(0% to 100% Load)	(Single Output) ±0.5%, max. (Dual Output) ±1.0%, max.
Ripple & noise (20 MHz bandwidth)(1)	100mV pk-pk, max.
Over-current protection	140% of FL, typ.
Short circuit protection	Indefinite(Automatic Recovery)
Temperature coefficient	±0.02%/°C
Capacitor load(2)	See table, max.
Transient Recovery Time(3)	250µs, typ.
Transient Response Deviation(3)	±3%, max.

INPUT SPECIFICATIONS	
Input Voltage Range	See table
Start up Time(Nominal Vin and constant resistive load)	20mS, typ.
Input Current(No-Load)	See table, max.
Input Current(Full-Load)	See table, typ.
Input Filter	Pi Type
Input Reflected Ripple Current(4)	35mA pk-pk

GENERAL SPECIFICATIONS	
Efficiency	See table, typ.
I/O Isolation Voltage(60sec)	Input/Output 1500~3500Vdc Case/Input & Output 1000Vdc
I/O Isolation Capacitance	500 pF, Typ.
I/O Isolation Resistance	1000 MΩ, min.
Switching Frequency	200kHz, typ.
Humidity	95% rel H
Reliability Calculated MTBF(MIL-HDBK-217 F)	>1.121 Mhrs
Safety Standard(5)	UL/cUL 60950-1 , 62368-1 IEC/EN 60950-1 , 62368-1
Safety Approvals(5)	UL/cUL 60950-1 , 62368-1 IEC/EN 60950-1 , 62368-1

EMC SPECIFICATIONS		
Radiated Emissions	EN55032	CLASS A
Conducted Emissions(6)	EN55032	CLASS A
ESD	IEC61000-4-2	Perf. Criteria A
RS	IEC61000-4-3	Perf. Criteria A
EFT	IEC61000-4-4	Perf. Criteria A
Surge (7)	IEC61000-4-5	Perf. Criteria A
CS	IEC61000-4-6	Perf. Criteria A
PFMF	IEC61000-4-8	Perf. Criteria A

PHYSICAL SPECIFICATIONS	
Case Material	Nickel-coated Brass
Pin Material	Φ1.0mm Brass Solder-coated
Potting Material	Epoxy (UL94V-0 rated)
Weight	31.0g
Dimensions	2.00"x1.00"x0.40"

ENVIRONMENT SPECIFICATIONS	
Operating Temperature	-40°C~85°C(See Derating Curve) -40°C~70°C(For 100% load)
Maximum Case Temperature	100°C
Storage Temperature	-40°C~125°C
Cooling	Nature Convection

ABSOLUTE MAXIMUM RATINGS(8)	
These are stress ratings. Exposure of devices to any of these conditions may adversely affect long-term reliability.	
Input Surge Voltage(100mS)	
12 Models	25 Vdc, max.
24 Models	50 Vdc, max.
48 Models	100 Vdc, max.
Soldering Temperature (1.5mm from case 10sec max.)	260°C, max.

The information and specifications contained in this data sheet are believed to be correct at time of publication. However, MOTIEN Technologies accepts no responsibility for consequences arising from printing errors or inaccuracies. Specifications are subject to change without notice. No rights under any patent accompany the sale of any such product(s) or information contained herein.

## V7 - 15W 2:1 Regulated Single & Dual output

### PART NUMBER STRUCTURE

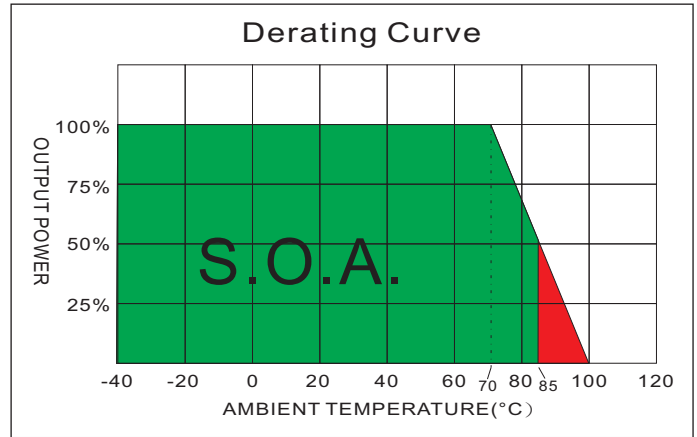
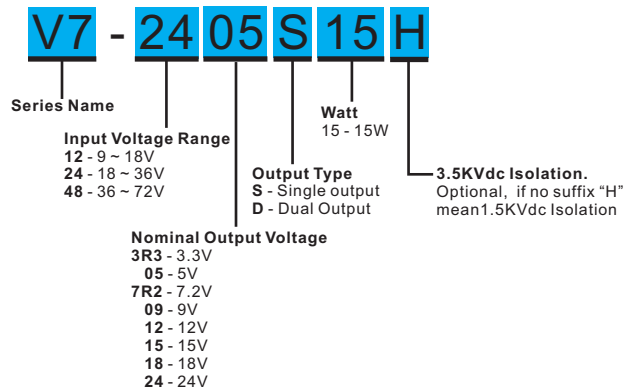

## MODEL SELECTION GUIDE

MODEL NUMBER	INPUT Voltage Range (Vdc)	INPUT Current		OUTPUT Voltage (Vdc)	OUTPUT Current		EFFICIENCY @FL (% , typ.)	Capacitor Load @FL (µF, max.)
		No-Load (mA, max.)	Full Load (mA, typ.)		Min. load (mA)	Full load (mA)		
V7-123R3S15	9-18	30	1031	3.3	0	3000	80	3300
V7-1205S15	9-18	30	1524	5	0	3000	82	3300
V7-127R2S15	9-18	30	1506	7.2	0	2083	83	2200
V7-1209S15	9-18	30	1470	9	0	1666	85	1000
V7-1212S15	9-18	30	1470	12	0	1250	85	1000
V7-1215S15	9-18	30	1470	15	0	1000	85	680
V7-1218S15	9-18	30	1470	18	0	833	85	470
V7-1224S15	9-18	30	1453	24	0	625	86	470
V7-123R3D15	9-18	30	1562	±3.3	0	±1500	80	±1000
V7-1205D15	9-18	30	1524	±5	0	±1500	82	±1000
V7-127R2D15	9-18	30	1506	±7.2	0	±1041	83	±680
V7-1209D15	9-18	30	1488	±9	0	±833	84	±470
V7-1212D15	9-18	30	1488	±12	0	±625	84	±470
V7-1215D15	9-18	30	1488	±15	0	±500	84	±330
V7-1218D15	9-18	30	1470	±18	0	±416	85	±220
V7-1224D15	9-18	30	1470	±24	0	±312	85	±220
V7-243R3S15	18-36	25	515	3.3	0	3000	80	3300
V7-2405S15	18-36	25	744	5	0	3000	84	3300
V7-247R2S15	18-36	25	744	7.2	0	2083	84	2200
V7-2409S15	18-36	25	735	9	0	1666	85	1000
V7-2412S15	18-36	25	735	12	0	1250	85	1000
V7-2415S15	18-36	25	726	15	0	1000	86	680
V7-2418S15	18-36	25	726	18	0	833	86	470
V7-2424S15	18-36	25	718	24	0	625	87	470
V7-243R3D15	18-36	25	515	±3.3	0	±1500	80	±1000
V7-2405D15	18-36	25	753	±5	0	±1500	83	±1000
V7-247R2D15	18-36	25	744	±7.2	0	±1041	84	±680
V7-2409D15	18-36	25	735	±9	0	±833	85	±470
V7-2412D15	18-36	25	726	±12	0	±625	86	±470
V7-2415D15	18-36	25	726	±15	0	±500	86	±330
V7-2418D15	18-36	25	718	±18	0	±416	87	±220
V7-2424D15	18-36	25	718	±24	0	±312	87	±220

## V7 - 15W 2:1 Regulated Single & Dual output

MODEL NUMBER	INPUT Voltage Range (Vdc)	INPUT Current		OUTPUT Voltage (Vdc)	OUTPUT Current		EFFICIENCY @FL (% , typ.)	Capacitor Load @FL (µF, max.)
		No-Load (mA, max.)	Full Load (mA, typ.)		Min. load (mA)	Full load (mA)		
V7-483R3S15	36-72	20	257	3.3	0	3000	80	3300
V7-4805S15	36-72	20	372	5	0	3000	84	3300
V7-487R2S15	36-72	20	372	7.2	0	2083	84	2200
V7-4809S15	36-72	20	367	9	0	1666	85	1000
V7-4812S15	36-72	20	363	12	0	1250	86	1000
V7-4815S15	36-72	20	359	15	0	1000	87	680
V7-4818S15	36-72	20	359	18	0	833	87	470
V7-4824S15	36-72	20	359	24	0	625	87	470
V7-483R3D15	36-72	20	257	±3.3	0	±1500	80	±1000
V7-4805D15	36-72	20	372	±5	0	±1500	84	±1000
V7-487R2D15	36-72	20	372	±7.2	0	±1041	84	±680
V7-4809D15	36-72	20	367	±9	0	±833	85	±470
V7-4812D15	36-72	20	363	±12	0	±625	86	±470
V7-4815D15	36-72	20	359	±15	0	±500	87	±330
V7-4818D15	36-72	20	359	±18	0	±416	87	±220
V7-4824D15	36-72	20	359	±24	0	±312	87	±220

Suffix "H" means 3.5KVdc isolation

### NOTE

1. Measured with 20MHz bandwidth and 1.0uF ceramic capacitor.
2. Tested by minimal Vin and constant resistive load.
3. Tested by normal Vin and 25% load step change ( 75%-50%-25% of Io).
4. Measured Input reflected ripple current with a simulated source inductance of 12uH.
5. Safety certificates are available for models with 1500Vdc isolation only.
6. Input filter components (C1,L,C2,C3) are used to help meet conducted emissions requirement for the module, which application refer to the EMI Filter of design & feature configuration..  
These components should be mounted as close as possible to the module; and all leads should be minimized to decrease radiated Noise.
7. An external filter capacitor is required if the module has to meet IEC61000-4-5.  
The filter capacitor Motien suggest: Nippon chemi-con KY series, 220uF/100V.
8. Exceeding the absolute ratings of the unit could cause damage. It is not allowed for continuous operating.
9. Operation under no-load conditions will not damage these devices, however they may not meet all listed specifications.

**TEST CONFIGURATIONS**

**Input Reflected Ripple Current Test Step**

Input reflected ripple current is measured through a source inductor  $L_{in}$  (12 $\mu$ H) and a source capacitor  $C_{in}$  (47 $\mu$ F, ESR<1.0 $\Omega$  at 100KHz) at nominal input and full load.

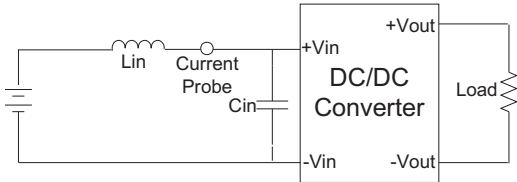

**EMI Filter**

Input filter components ( $C_1, L, C_2, C_3$ ) are used to help meet conducted emissions requirement for the module. These components should be mounted as close as possible to the module; and all leads should be minimized to decrease radiated noise.

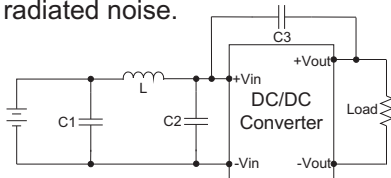

	C1	L	C2	C3
V7-12XXXXXX	330 $\mu$ F/100V	12 $\mu$ H	100 $\mu$ F/100V	1808,1000pF/3KV
V7-24XXXXXX	330 $\mu$ F/100V	12 $\mu$ H	100 $\mu$ F/100V	1808,1000pF/3KV
V7-48XXXXXX	330 $\mu$ F/100V	12 $\mu$ H	100 $\mu$ F/100V	1808,1000pF/3KV

**Output Ripple & Noise Measurement Test**

Use a capacitor  $C_{out}$  (1.0 $\mu$ F) measurement. The Scope measurement bandwidth is 0-20MHz.

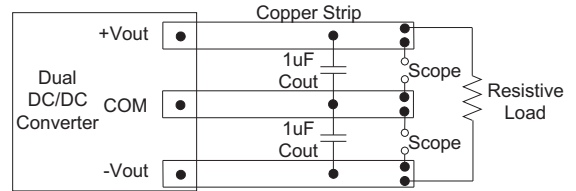

**ELECTRICAL CHARACTERISTIC CURVES**

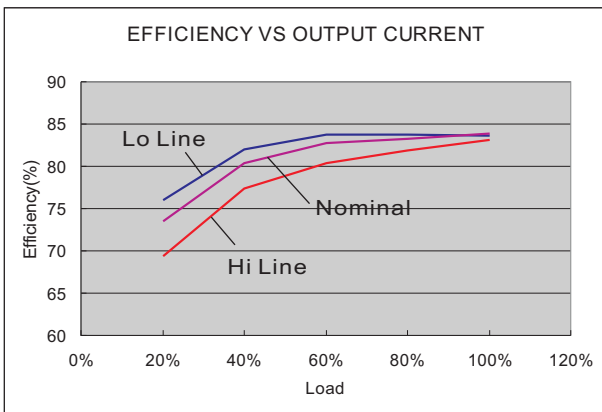

12 Models

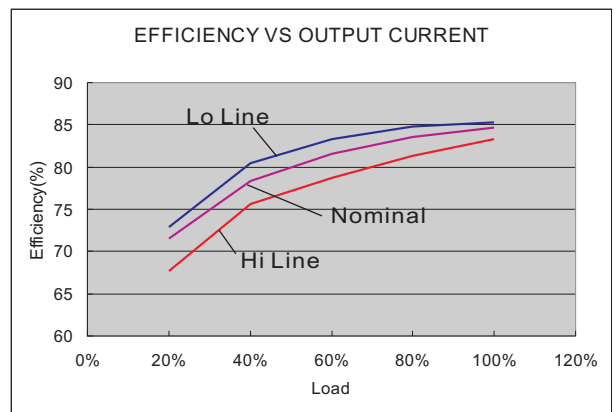

24 Models

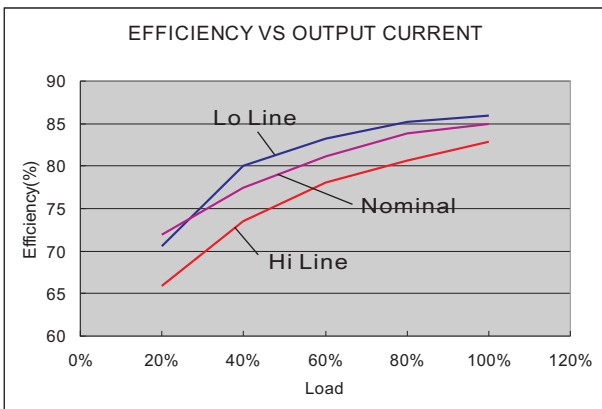

48 Models

The models listed above is just for standard type. If you need the special specification product, please contact our service member by telephone presented in shortform cover or e-mail to : sales@motien.com.tw

# V7 - 15W 2:1 Regulated Single & Dual output

## MECHANICAL SPECIFICATIONS

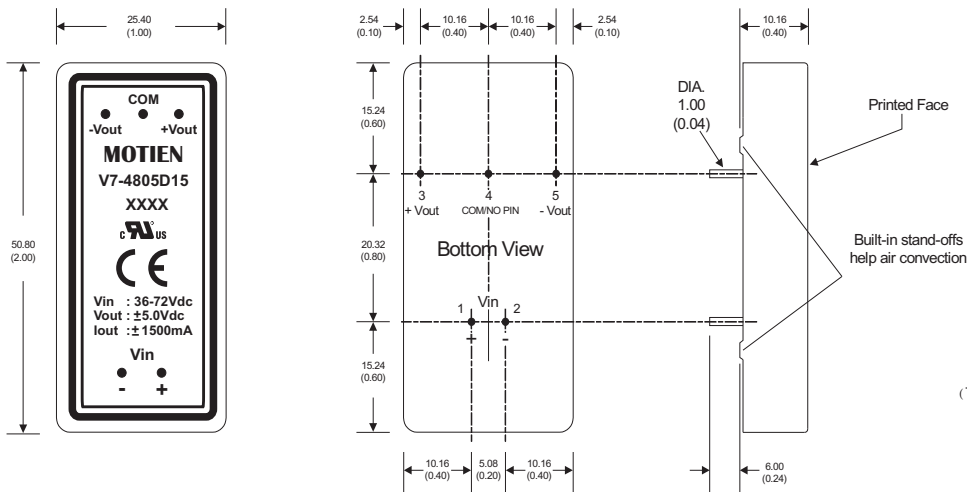

PIN CONNECTIONS		
PIN NUMBER	SINGLE	DUAL
1	+V Input	+V Input
2	-V Input	-V Input
3	+V Output	+V Output
4	N.P.	Common
5	-V Output	-V Output

(The Pin Connection of high isolation one is the same with normal one.)

- All dimensions are typical in millimeters ( inches ).
1. Pin diameter:  $1.0 \pm 0.05$  (  $0.04 \pm 0.002$  )
  2. Pin pitch and length tolerance:  $\pm 0.35$  (  $\pm 0.014$  )
  3. Case Tolerance:  $\pm 0.5$  (  $\pm 0.02$  )