

# VD-6W Series



6W 2:1 Regulated Single & Dual output

## Features

- Wide 2:1 Input Range
- Full SMD Technology
- 1500 VDC Isolation, Up to 3500 VDC
- Continuous Short Circuit Protection
- Efficiency up to 83%
- -40 ~ 85°C Operation Temperature Range
- Metal Case Standard, Optional Plastic Case
- CB & UL Certified Available For Metal Case Models



The VD series is a family of cost effective 6.0W single & dual output DC-DC converters. These converters are consisted with Nickel-coated copper in a 24-pin DIL package with high performance features such as 1500 VDC ~ 3500VDC input/output isolation voltage, continuous short circuit protection with automatic restart and tight line / load regulation. Devices are encapsulated using flame retardant resin. Input voltages of 12,24 and 48 with output voltage of 3.3,5,7,2,9,12,15,18,24, ±3.3, ±5, ±7.2, ±9, ±12, ±15, ±18 and ±24 Vdc. High performance features include high efficiency operation up to 75% and output voltage accuracy of ±1% maximum.

All specifications typical at Ta=25°C, nominal input voltage and full load unless otherwise specified

OUTPUT SPECIFICATIONS	
Voltage accuracy	±1%
Line regulation	±0.5%
Load regulation	±0.5%
	(Output 3.3V / ±3.3V Model) ±1.5%
Ripple & noise (20 MHz bandwidth)(1)	60mV pk-pk
Short circuit protection	Indefinite(Automatic Recovery)
Temperature coefficient	±0.02%/°C
Capacitor load(2)	See table

INPUT SPECIFICATIONS	
Voltage Range	See table
Max. Input Current	See table
No-Load Input Current	See table
Input Filter	PI Type
Input Reflected Ripple Current(3)	35mA pk-pk

GENERAL SPECIFICATIONS	
Efficiency	See table, typ.
I/O Isolation Voltage(60sec)	1500~3500Vdc
Input/Output	1500~3500Vdc
Metal Case/Input & Output	1000Vdc
I/O Isolation Capacitance	500 pF, typ.
I/O Isolation Resistance	1000M Ohm
Switching Frequency	266kHz, typ.
Humidity	95% rel H
Reliability Calculated MTBF(MIL-HDBK-217 F)	>1.121 Mhrs
Safety Standard	UL/cUL 60950-1 , 62368-1 IEC/EN 60950-1 , 62368-1
Safety Approvals	UL/cUL 60950-1 , 62368-1 IEC/EN 60950-1 , 62368-1

PHYSICAL SPECIFICATIONS	
Case Material	Nickel-coated Copper
	Non-conductive Black Plastic(UL94V-0 rated)
Base Material	Non-conductive Black Plastic(UL94V-0 rated)
Pin Material	Φ0.5mm Brass Solder-coated
Potting Material	Epoxy (UL94V-0 rated)
Weight	17.0g(Metal Case)/13.5g(Plastic Case)
Dimensions	1.25"x0.8"x0.4"

ENVIRONMENT SPECIFICATIONS	
Operating Temperature	-40°C~85°C(See Derating Curve)
Maximum Case Temperature	100°C
Storage Temperature	-40°C~125°C
Cooling	Nature Convection

ABSOLUTE MAXIMUM RATINGS(4)	
These are stress ratings. Exposure of devices to any of these conditions may adversely affect long-term reliability.	
Input Surge Voltage(100mS)	
12 Models	24 Vdc, max.
24 Models	40 Vdc, max.
48 Models	80 Vdc, max.
Soldering Temperature (1.5mm from case 10sec. max.)	260°C, max.

EMC SPECIFICATIONS		
Radiated Emissions	EN55032	CLASS A
Conducted Emissions (5)	EN55032	CLASS A
ESD	IEC 61000-4-2	Perf. Criteria A
RS	IEC 61000-4-3	Perf. Criteria A
EFT (6)	IEC 61000-4-4	Perf. Criteria A
Surge (6)	IEC 61000-4-5	Perf. Criteria A
CS	IEC 61000-4-6	Perf. Criteria A
PFMF	IEC 61000-4-8	Perf. Criteria A

The information and specifications contained in this data sheet are believed to be correct at time of publication. However, MOTIEN Technologies accepts no responsibility for consequences arising from printing errors or inaccuracies. Specifications are subject to change without notice. No rights under any patent accompany the sale of any such product(s) or information contained herein.

## VD - 6W 2:1 Regulated Single & Dual output

### PART NUMBER STRUCTURE

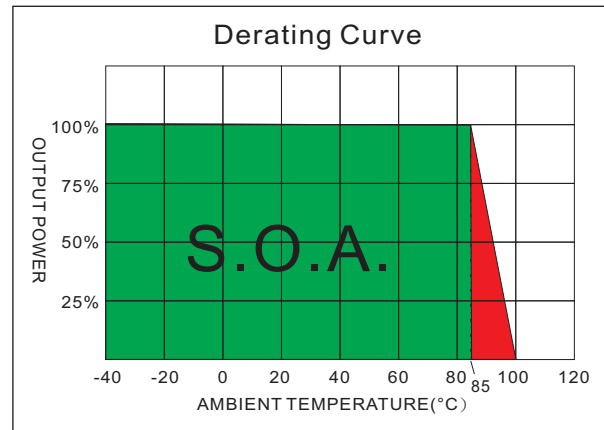
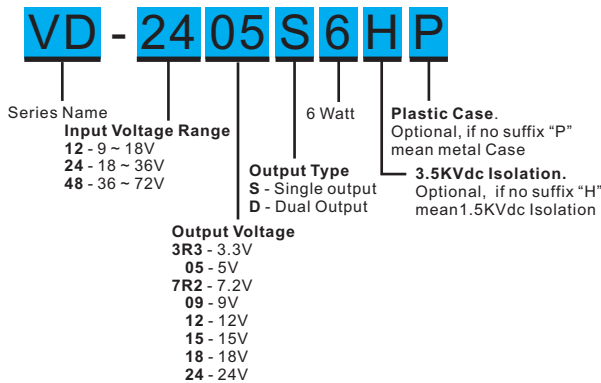

### MODEL SELECTION GUIDE

MODEL NUMBER	INPUT Voltage Range (Vdc)	INPUT Current		OUTPUT Voltage (Vdc)	OUTPUT Current		EFFICIENCY @FL (% , typ.)	Capacitor Load @FL (µF, max.)
		No-Load (mA, max.)	Full Load (mA, typ.)		Min. load (mA)	Full load (mA)		
VD-123R3S6	9-18	30	527	3.3	0	1400	73	1000
VD-1205S6	9-18	30	649	5	0	1200	77	1000
VD-127R2S6	9-18	30	641	7.2	0	833	78	680
VD-1209S6	9-18	30	641	9	0	666	78	680
VD-1212S6	9-18	30	617	12	0	500	81	330
VD-1215S6	9-18	30	625	15	0	400	80	220
VD-1218S6	9-18	30	625	18	0	333	80	68
VD-1224S6	9-18	30	625	24	0	250	80	68
VD-123R3D6	9-18	30	527	±3.3	0	±909	73	±680
VD-1205D6	9-18	30	649	±5	0	±600	77	±330
VD-127R2D6	9-18	30	625	±7.2	0	±416	80	±220
VD-1209D6	9-18	30	625	±9	0	±333	80	±220
VD-1212D6	9-18	30	625	±12	0	±250	80	±100
VD-1215D6	9-18	30	632	±15	0	±200	79	±47
VD-1218D6	9-18	30	625	±18	0	±166	80	±33
VD-1224D6	9-18	30	625	±24	0	±125	80	±33
VD-243R3S6	18-36	20	256	3.3	0	1400	75	1000
VD-2405S6	18-36	20	313	5	0	1200	80	1000
VD-247R2S6	18-36	20	304	7.2	0	833	82	680
VD-2409S6	18-36	20	304	9	0	666	82	680
VD-2412S6	18-36	20	313	12	0	500	80	330
VD-2415S6	18-36	20	304	15	0	400	82	220
VD-2418S6	18-36	20	305	18	0	333	82	68
VD-2424S6	18-36	20	305	24	0	250	82	68
VD-243R3D6	18-36	20	333	±3.3	0	±909	75	±680
VD-2405D6	18-36	20	321	±5	0	±600	78	±330
VD-247R2D6	18-36	20	301	±7.2	0	±416	83	±220
VD-2409D6	18-36	20	301	±9	0	±333	83	±220
VD-2412D6	18-36	20	312	±12	0	±250	80	±100
VD-2415D6	18-36	20	312	±15	0	±200	80	±47
VD-2418D6	18-36	20	312	±18	0	±166	80	±33
VD-2424D6	18-36	20	312	±24	0	±125	80	±33

Suffix "H" means 3.5KVdc isolation

Suffix "P" means Plastic case instead of standard Metal Case

## VD - 6W 2:1 Regulated Single & Dual output

MODEL NUMBER	INPUT Voltage Range (Vdc)	INPUT Current		OUTPUT Voltage (Vdc)	OUTPUT Current		EFFICIENCY @FL (% , typ.)	Capacitor Load @ FL (μF, max.)
		No-Load (mA, max.)	Full Load (mA, typ.)		Min. load (mA)	Full load (mA)		
VD-483R3S6	36-72	12	128	3.3	0	1400	75	1000
VD-4805S6	36-72	12	156	5	0	1200	80	1000
VD-487R2S6	36-72	12	152	7.2	0	833	82	680
VD-4809S6	36-72	12	152	9	0	666	82	680
VD-4812S6	36-72	12	156	12	0	500	80	330
VD-4815S6	36-72	12	151	15	0	400	83	220
VD-4818S6	36-72	12	151	18	0	333	83	68
VD-4824S6	36-72	12	151	24	0	250	83	68
VD-483R3D6	36-72	12	171	±3.3	0	±909	73	±680
VD-4805D6	36-72	12	158	±5	0	±600	79	±330
VD-487R2D6	36-72	12	158	±7.2	0	±416	79	±220
VD-4809D6	36-72	12	158	±9	0	±333	79	±220
VD-4812D6	36-72	12	156	±12	0	±250	80	±100
VD-4815D6	36-72	12	156	±15	0	±200	80	±47
VD-4818D6	36-72	12	156	±18	0	±166	80	±33
VD-4824D6	36-72	12	156	±24	0	±125	80	±33

Suffix "H" means 3.5KVdc isolation

Suffix "P" means Plastic case instead of standard Metal Case

### NOTE

1. Ripple/Noise measured with a 1uF ceramic capacitor.
2. Test by nominal input voltage and constant resistor load.
3. Measured Input reflected ripple current with a simulated source inductance of 12uH.
4. Exceeding the absolute ratings of the unit could cause damage. It is not allowed for continuous operating.
5. Input filter components are be required to help meet conducted emission class A, which application refer to the EMI Filter of design & feature configuration.
6. An external filter capacitor is required if the module has to meet IEC 61000-4-4 and IEC 61000-4-5.  
The filter capacitor Motien suggest: Nippon - chemi - con KY series, 220uF/100V.

### TEST CONFIGURATIONS

#### Input Reflected Ripple Current Test Step

Input reflected ripple current is measured through a source inductor  $L_{in}$ (12uH) and a source capacitor  $C_{in}$ (47uF, ESR<1.0Ω at 100KHz) at nominal input and full load.

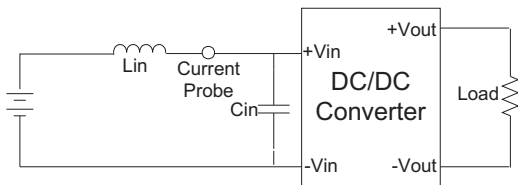

#### Output Ripple & Noise Measurement Test

Use a capacitor  $C_{out}$ (1.0uF) measurement.  
The Scope measurement bandwidth is 0-20MHz.

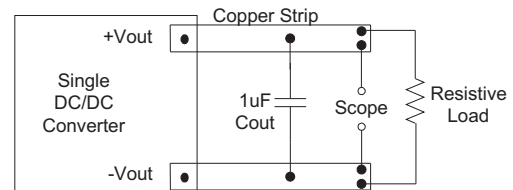

#### EMI Filter

Input filter components ( $C_1$ ,  $L$ ) are used to help meet conducted emissions requirement for the module. These components should be mounted as close as possible to the module; and all leads should be minimized to decrease radiated noise.

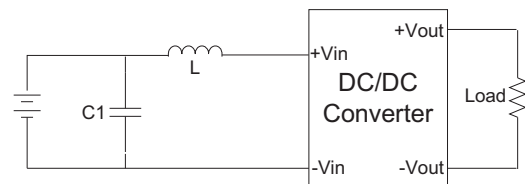

C1	L
100uF, 100V	12uH

**ELECTRICAL CHARACTERISTIC CURVES**

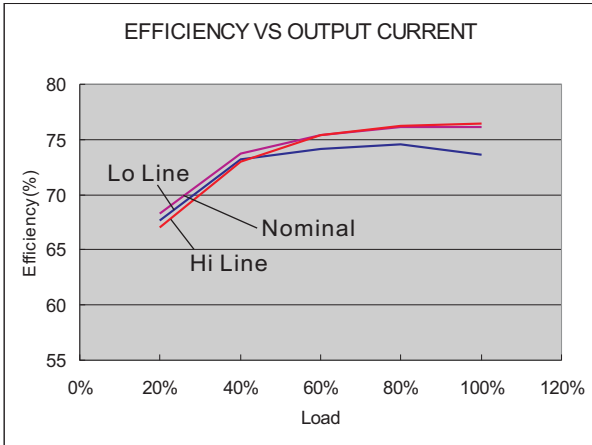

12 Models

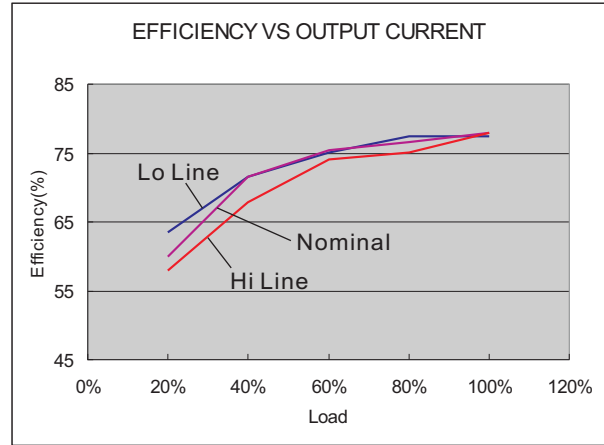

24 Models

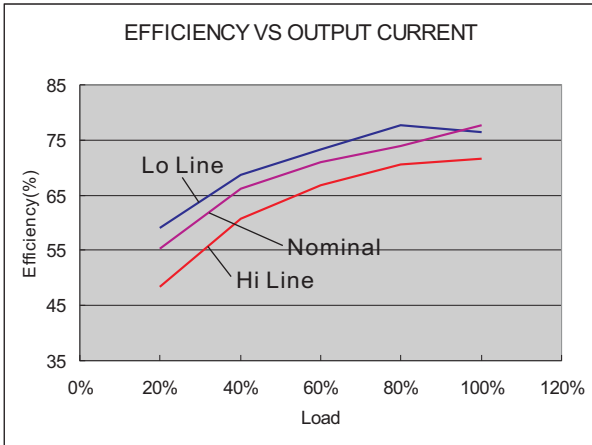

48 Models

**MECHANICAL SPECIFICATIONS**

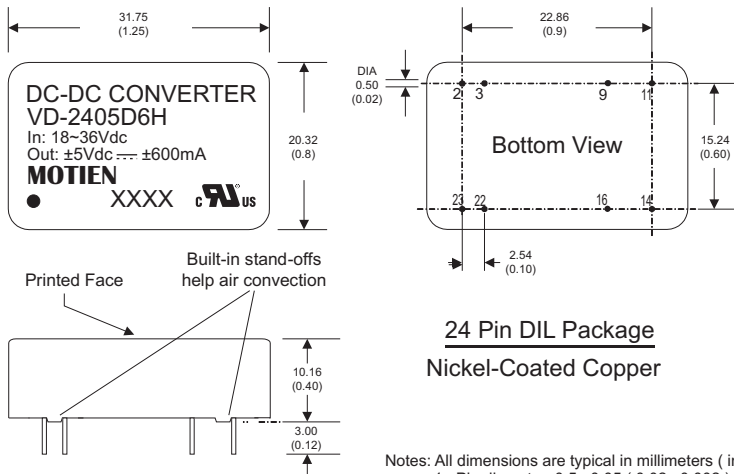

**24 Pin DIL Package**  
Nickel-Coated Copper

- Notes: All dimensions are typical in millimeters ( inches ).
1. Pin diameter:  $0.5 \pm 0.05$  (  $0.02 \pm 0.002$  )
  2. Pin pitch and length tolerance:  $\pm 0.35$  (  $\pm 0.014$  )
  3. Case Tolerance:  $\pm 0.5$  (  $\pm 0.02$  )

PIN CONNECTIONS		
PIN NUMBER	SINGLE	DUAL
2	-V Input	-V Input
3	-V Input	-V Input
9	N.P.	Common
11	N.C.	-V Output
14	+V Output	+V Output
16	-V Output	Common
22	+V Input	+V Input
23	+V Input	+V Input

(The Pin Connection of high isolation one is the same with normal one.)

**MECHANICAL SPECIFICATIONS**

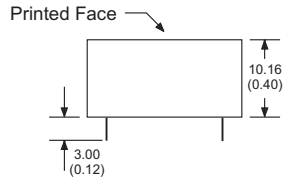
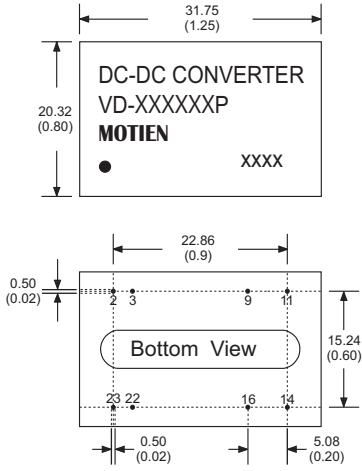

For "P" Case  
24 Pin DIL Package  
 Non-Conductive Plastic

- Notes: All dimensions are typical in millimeters ( inches ).
1. Pin diameter:  $0.5 \pm 0.05$  (  $0.02 \pm 0.002$  )
  2. Pin pitch and length tolerance:  $\pm 0.35$  (  $\pm 0.014$  )
  3. Case Tolerance:  $\pm 0.5$  (  $\pm 0.02$  )

PIN CONNECTIONS		
PIN NUMBER	SINGLE	DUAL
2	-V Input	-V Input
3	-V Input	-V Input
9	N.P.	Common
11	N.C.	-V Output
14	+V Output	+V Output
16	-V Output	Common
22	+V Input	+V Input
23	+V Input	+V Input

(The Pin Connection of high isolation one is the same with normal one.)