

VD-8W Series



8W 2:1 Regulated Single & Dual output

Features

- Wide 2:1 Input Range
- Full SMD Technology
- 1500 VDC Isolation
- Continuous Short Circuit Protection
- Efficiency up to 85%
- -40 ~ 85°C Operation Temperature Range
- High Power Density: 8W in DIL-24 Package



The VD-8W series are a family of high performance 8W single & dual output DC/DC converters. These converters are consisted with nickel plated copper Dual in Line 24 pin package. The high performance features include: Synchronous Rectification, high efficiency and tight line/load regulation. Devices are encapsulated with high grade flameproof epoxy with UL94V-0 recognize. Input voltages of 12, 24 and 48 with output voltage of 3.3, 5, 7.2, 9, 12, 15, ± 5 , ± 7.2 , ± 9 , ± 12 , ± 15 . High performance features include high efficiency operation up to 85% and output voltage accuracy of $\pm 1\%$ maximum.

All specifications typical at $T_a=25^\circ\text{C}$, nominal input voltage and full load unless otherwise specified

OUTPUT SPECIFICATIONS	
Voltage accuracy	$\pm 1\%$
Line Regulation	$\pm 0.5\%$
Load Regulation (Single, $I_o=0\%$ to 100%)	$\pm 0.5\%$
(Dual, $I_o=0\%$ to 100%)	$\pm 1.0\%$
($I_o=0\%$ to 100%, only 3.3V)	$\pm 1.5\%$
Cross Regulation (Dual Output) (1)	$\pm 5\%$
Over Current Protection	150% of FL, typ.
Ripple & noise (20 MHz bandwidth)(2)	75mV pk-pk
Short circuit protection	Indefinite(hiccup) (Automatic Recovery)
Temperature coefficient	$\pm 0.02\%/^\circ\text{C}$
Capacitor load(3)	See table

INPUT SPECIFICATIONS	
Voltage Range	See table
Max. Input Current	See table
No-Load Input Current	See table
Input Filter	PI Type
Input Reflected Ripple Current(4)	35mA pk-pk

GENERAL SPECIFICATIONS	
Efficiency	See table, typ.
I/O Isolation Voltage(60sec)	
Input/Output	1500Vdc
Metal Case/Input & Output	1000Vdc
I/O Isolation Capacitance	1000 pF, typ.
I/O Isolation Resistance	1000M Ohm
Switching Frequency	330kHz, typ.
Humidity	95% rel H
Reliability Calculated MTBF(MIL-HDBK-217 F)	>0.91 Mhrs
Safety Standard	UL/cUL 60950-1, 62368-1 IEC/EN 60950-1, 62368-1
Safety Approvals	UL/cUL 60950-1, 62368-1 IEC/EN 60950-1, 62368-1

EMC CHARACTERISTICS		
Radiated Emissions	EN55032	CLASS A
Conducted Emissions(7)	EN55032	CLASS A
ESD	IEC61000-4-2	Perf. Criteria A
RS	IEC61000-4-3	Perf. Criteria A
EFT(8)	IEC61000-4-4	Perf. Criteria A
Surge (8)	IEC61000-4-5	Perf. Criteria A
CS	IEC61000-4-6	Perf. Criteria A
PFMF	IEC61000-4-8	Perf. Criteria A

PHYSICAL SPECIFICATIONS	
Case Material	Nickel-coated Copper
Pin Material	$\phi 0.5\text{mm}$ Brass Solder-coated
Potting Material	Epoxy (UL94V-0 rated)
Weight	17.0g
Dimensions	1.25"x0.8"x0.4"

ENVIRONMENT SPECIFICATIONS	
Operating Temperature	$-40^\circ\text{C} \sim 85^\circ\text{C}$ (See Derating Curve) $-40^\circ\text{C} \sim 60^\circ\text{C}$ (For 100% load)
Maximum Case Temperature	100°C
Storage Temperature	$-40^\circ\text{C} \sim 125^\circ\text{C}$
Cooling	Nature Convection

ABSOLUTE MAXIMUM RATINGS(9)	
These are stress ratings. Exposure of devices to any of these conditions may adversely affect long-term reliability.	
Input Surge Voltage(100mS)	
12 Models	25 Vdc, max.
24 Models	50 Vdc, max.
48 Models	100 Vdc, max.
Soldering Temperature (1.5mm from case 10sec max.)	260°C , max.

The information and specifications contained in this data sheet are believed to be correct at time of publication. However, MOTIEN Technologies accepts no responsibility for consequences arising from printing errors or inaccuracies. Specifications are subject to change without notice. No rights under any patent accompany the sale of any such product(s) or information contained herein.

VD - 8W 2:1 Regulated Single & Dual output

PART NUMBER STRUCTURE

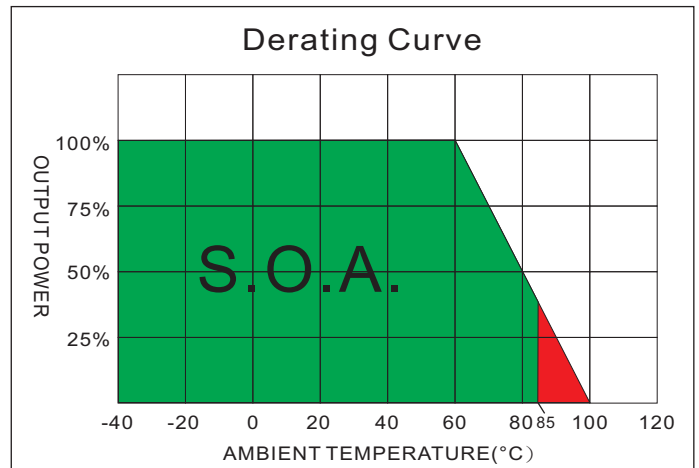
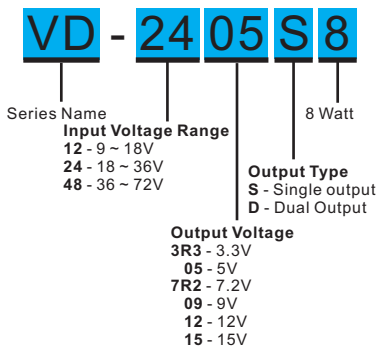

MODEL SELECTION GUIDE

MODEL NUMBER	INPUT Voltage Range (Vdc)	INPUT Current		OUTPUT Voltage (Vdc)	OUTPUT Current		EFFICIENCY @FL (% , typ.)	Capacitor Load @FL (µF, max.)
		No-Load (mA, max.)	Full Load (mA, typ.)		Min. load (mA)	Full load (mA)		
VD-123R3S8	9-18	20	687	3.3	0	2000	80	3300
VD-1205S8	9-18	20	762	5	0	1500	82	2200
VD-127R2S8	9-18	20	803	7.2	0	1111	83	1000
VD-1209S8	9-18	20	794	9	0	888	84	470
VD-1212S8	9-18	20	784	12	0	665	85	470
VD-1215S8	9-18	20	803	15	0	535	83	220
VD-1205D8	9-18	20	813	±5	0	±800	82	±1000
VD-127R2D8	9-18	20	803	±7.2	0	±555	83	±470
VD-1209D8	9-18	20	794	±9	0	±444	84	±330
VD-1212D8	9-18	20	794	±12	0	±335	84	±220
VD-1215D8	9-18	20	794	±15	0	±265	84	±100
VD-243R3S8	18-36	15	344	3.3	0	2000	80	3300
VD-2405S8	18-36	15	381	5	0	1500	82	2200
VD-247R2S8	18-36	15	396	7.2	0	1111	84	1000
VD-2409S8	18-36	15	387	9	0	888	86	470
VD-2412S8	18-36	15	392	12	0	665	85	470
VD-2415S8	18-36	15	397	15	0	535	84	220
VD-2405D8	18-36	15	407	±5	0	±800	82	±1000
VD-247R2D8	18-36	15	396	±7.2	0	±555	84	±470
VD-2409D8	18-36	15	392	±9	0	±444	85	±330
VD-2412D8	18-36	15	402	±12	0	±335	83	±220
VD-2415D8	18-36	15	392	±15	0	±265	85	±100
VD-483R3S8	36-72	15	172	3.3	0	2000	80	3300
VD-4805S8	36-72	15	191	5	0	1500	82	2200
VD-487R2S8	36-72	15	198	7.2	0	1111	84	1000
VD-4809S8	36-72	15	198	9	0	888	84	680
VD-4812S8	36-72	15	198	12	0	665	84	470
VD-4815S8	36-72	15	198	15	0	535	84	220
VD-4805D8	36-72	15	203	±5	0	±800	82	±1000
VD-487R2D8	36-72	15	198	±7.2	0	±555	84	±1000
VD-4809D8	36-72	15	198	±9	0	±444	84	±680
VD-4812D8	36-72	15	196	±12	0	±335	85	±220
VD-4815D8	36-72	15	196	±15	0	±265	85	±100

VD - 8W 2:1 Regulated Single & Dual output

NOTE

1. One load is 25% to 100% load, the other load is 100% load, the output voltage variable rate is within $\pm 5\%$.
2. Ripple/Noise measured with a 1uF ceramic capacitor.
3. Test by nominal input voltage and constant resistor load.
4. Measured Input reflected ripple current with a simulated source inductance of 12uH.
5. Operation under no-load and 10% conditions will not damage these devices, however they may not meet all listed specifications.
6. It's necessary to add minimum capacitor in output for some models, please check single model datasheet for detail value.
7. Input filter components (C1, L) are used to help meet conducted emissions requirement for the module. These components should be mounted as close as Possible to the module; and all leads should be minimized to decrease radiated noise.
8. An external filter capacitor is required if the module has to meet IEC61000-4-4 and IEC61000-4-5. The filter capacitor Motien suggest: Nippon - chemi - con KY series, 220uF/100V.
9. Exceeding the absolute ratings of the unit could cause damage. It is not allowed for continuous operating.

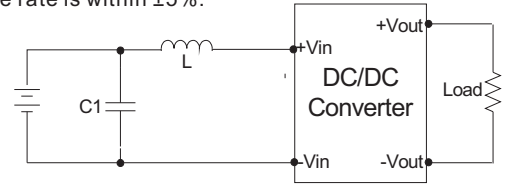

	C1	L
VD-12XXXXX	100uF, 100V	12uH
VD-24XXXXX	100uF, 100V	12uH
VD-48XXXXX	100uF, 100V	12uH

TEST CONFIGURATIONS

Input Reflected Ripple Current Test Step

Input reflected ripple current is measured through a source inductor L_{in} (12uH) and a source capacitor C_{in} (47uF, ESR<1.0Ω at 100KHz) at nominal input and full load.

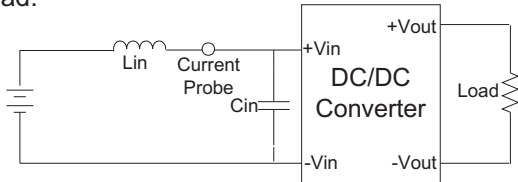

Output Ripple & Noise Measurement Test

Use a capacitor C_{out} (1.0uF) measurement. The Scope measurement bandwidth is 0-20MHz.

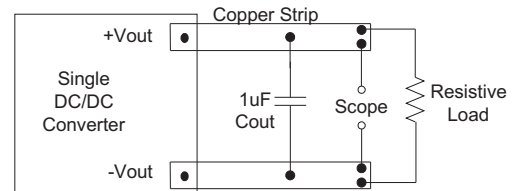

ELECTRICAL CHARACTERISTIC CURVES

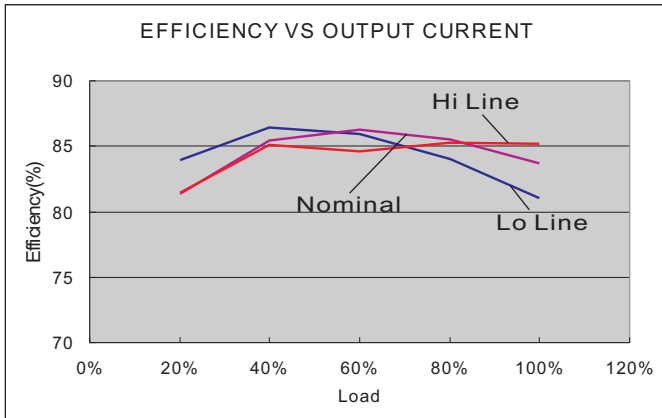

12 Models

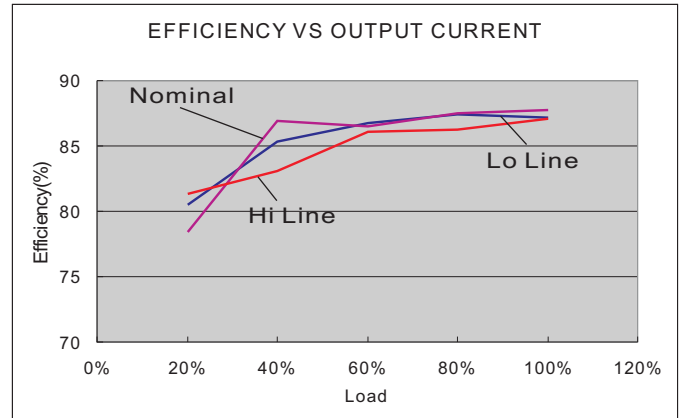

24 Models

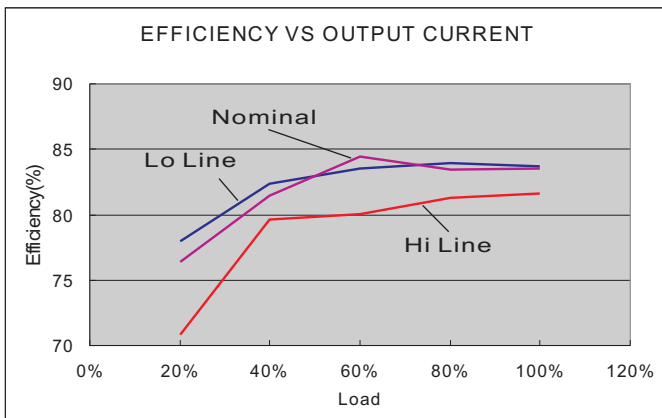

48 Models

The models listed above is just for standard type. If you need the special specification product, please contact our service member by telephone presented in shortform cover or e-mail to : sales@motien.com.tw

MECHANICAL SPECIFICATIONS

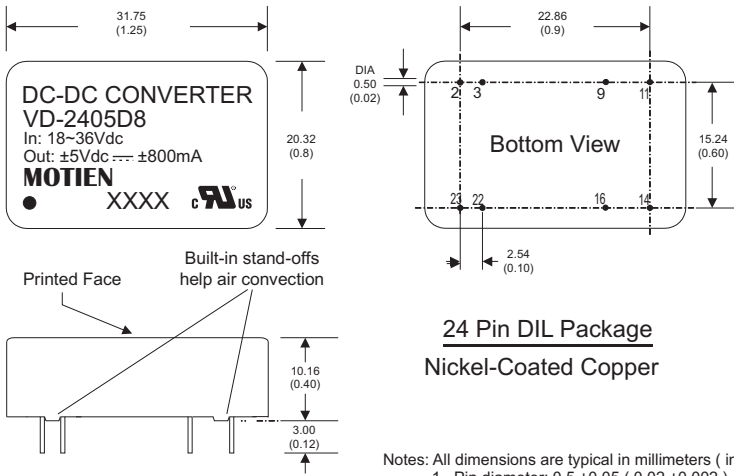

24 Pin DIL Package
Nickel-Coated Copper

- Notes: All dimensions are typical in millimeters (inches).
1. Pin diameter: 0.5 ± 0.05 (0.02 ± 0.002)
 2. Pin pitch and length tolerance: ± 0.35 (± 0.014)
 3. Case Tolerance: ± 0.5 (± 0.02)

PIN CONNECTIONS		
PIN NUMBER	SINGLE	DUAL
2	-V Input	-V Input
3	-V Input	-V Input
9	N.P.	Common
11	N.C.	-V Output
14	+V Output	+V Output
16	-V Output	Common
22	+V Input	+V Input
23	+V Input	+V Input