

VK-5W Series

5W 4:1 Regulated Single & Dual output

Features

- Wide 4:1 Input Range
- Full SMD Technology
- 1500 VDC Isolation, Up to 3500 VDC
- Continuous Short Circuit Protection
- Efficiency up to 84%
- -40 ~ 85°C Operation Temperature Range
- Metal Case Standard, Optional Plastic Case



The VK series is a family of cost effective 5.0W single & dual output DC-DC converters. These converters are consisted with Nickel-coated copper in a 24-pin DIL package with high performance features such as 1500 VDC ~ 3500VDC input/output isolation voltage, continuous short circuit protection with automatic restart and tight line / load regulation. Devices are encapsulated using flame retardant resin. Input voltages of 24 and 48 with output voltage of 3.3, 5, 7.2, 9, 12, 15, 18, 24, ± 3.3 , ± 5 , ± 7.2 , ± 9 , ± 12 , ± 15 , ± 18 and ± 24 Vdc. High performance features include high efficiency operation up to 84% and output voltage accuracy of $\pm 1\%$ maximum.

All specifications typical at Ta=25°C, nominal input voltage and full load unless otherwise specified

OUTPUT SPECIFICATIONS	
Voltage accuracy	$\pm 1\%$
Line regulation	$\pm 0.5\%$
Load regulation	$\pm 0.5\%$
	(Output 3.3V / ± 3.3 V Model) $\pm 1.5\%$
Ripple & noise (20 MHz bandwidth)(1)	60mV pk-pk
Short circuit protection	Indefinite(Automatic Recovery)
Temperature coefficient	$\pm 0.02\%/^{\circ}\text{C}$
Capacitor load(2)	See table

INPUT SPECIFICATIONS	
Voltage Range	See table
Max. Input Current	See table
No-Load Input Current	See table
Input Filter	PI Type
Input Reflected Ripple Current(3)	35mA pk-pk

GENERAL SPECIFICATIONS	
Efficiency	See table, typ
I/O Isolation Voltage(60sec)	
Input/Output	1500~3500Vdc
Metal Case/Input & Output	1000Vdc
I/O Isolation Capacitance	500 pF Typ.
I/O Isolation Resistance	1000M Ohm
Switching Frequency	Typical 266kHz
Humidity	95% rel H
Reliability Calculated MTBF(MIL-HDBK-217 F)	>1.121 Mhrs
Safety Standard : (designed to meet)	IEC 60950-1

EMC SPECIFICATIONS		
Radiated Emissions	EN55032	CLASS A
Conducted Emissions (4)	EN55032	CLASS A
ESD	IEC 61000-4-2	Perf. Criteria A
RS	IEC 61000-4-3	Perf. Criteria A
EFT	IEC 61000-4-4	Perf. Criteria A
Surge (5)	IEC 61000-4-5	Perf. Criteria A
CS	IEC 61000-4-6	Perf. Criteria A
PFMF	IEC 61000-4-8	Perf. Criteria A

PHYSICAL SPECIFICATIONS	
Case Material	Nickel-coated Copper
	Non-conductive Black Plastic(UL94V-0 rated)
Base Material	Non-conductive Black Plastic(UL94V-0 rated)
Pin Material	$\Phi 0.5$ mm Brass Solder-coated
Potting Material	Epoxy (UL94V-0 rated)
Weight	17.0g(Metal Case)/13.5g(Plastic Case)
Dimensions	1.25"x0.8"x0.4"

ENVIRONMENT SPECIFICATIONS	
Operating Temperature	-40°C~85°C
Maximum Case Temperature	100°C
Storage Temperature	-40°C~125°C
Cooling	Nature Convection

ABSOLUTE MAXIMUM RATINGS(6)	
These are stress ratings. Exposure of devices to any of these conditions may adversely affect long-term reliability.	
Input Surge Voltage(100mS)	
24 Models	40 Vdc, max.
48 Models	80 Vdc, max.
Soldering Temperature	260°C, max.
(1.5mm from case 10sec max.)	

VK - 5W 4:1 Regulated Single & Dual output

PART NUMBER STRUCTURE

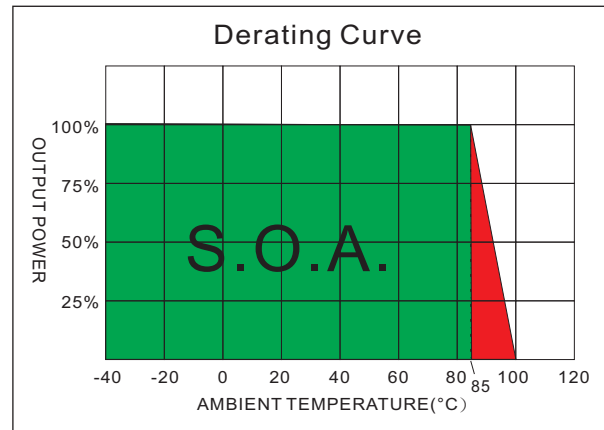
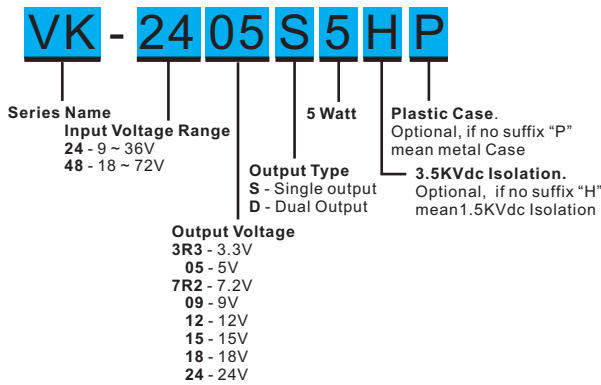

MODEL SELECTION GUIDE

MODEL NUMBER	INPUT Voltage Range (Vdc)	INPUT Current		OUTPUT Voltage (Vdc)	OUTPUT Current		EFFICIENCY @FL (% , typ.)	Capacitor Load @FL (µF , max.)
		No-Load (mA, max.)	Full Load (mA, typ.)		Min. load (mA)	Full load (mA)		
VK-243R3S5	9-36	18	238.3	3.3	0	1300	75	1000
VK-2405S5	9-36	18	260.4	5	0	1000	80	680
VK-247R2S5	9-36	18	260.4	7.2	0	694	80	470
VK-2409S5	9-36	18	257.2	9	0	555	81	220
VK-2412S5	9-36	18	254.1	12	0	416	82	100
VK-2415S5	9-36	18	251	15	0	333	83	100
VK-2418S5	9-36	18	260.4	18	0	277	80	68
VK-2424S5	9-36	18	260.4	24	0	208	80	47
VK-243R3D5	9-36	18	281.5	±3.3	0	±757	74	±470
VK-2405D5	9-36	18	260.4	±5	0	±500	80	±330
VK-247R2D5	9-36	18	260.4	±7.2	0	±347	80	±100
VK-2409D5	9-36	18	257.2	±9	0	±277	81	±68
VK-2412D5	9-36	18	254.1	±12	0	±208	82	±47
VK-2415D5	9-36	18	254.1	±15	0	±166	82	±47
VK-2418D5	9-36	18	260.4	±18	0	±138	80	±22
VK-2424D5	9-36	18	260.4	±24	0	±104	80	±22
VK-483R3S5	18-72	15	119.2	3.3	0	1300	75	1000
VK-4805S5	18-72	15	130.2	5	0	1000	80	680
VK-487R2S5	18-72	15	130.2	7.2	0	694	80	470
VK-4809S5	18-72	15	128.6	9	0	555	81	220
VK-4812S5	18-72	15	124	12	0	416	84	100
VK-4815S5	18-72	15	125.5	15	0	333	83	100
VK-4818S5	18-72	15	130.2	18	0	277	80	68
VK-4824S5	18-72	15	130.2	24	0	208	80	47
VK-483R3D5	18-72	15	140.7	±3.3	0	±757	74	±470
VK-4805D5	18-72	15	130.2	±5	0	±500	80	±330
VK-487R2D5	18-72	15	130.2	±7.2	0	±347	80	±100
VK-4809D5	18-72	15	128.6	±9	0	±277	81	±68
VK-4812D5	18-72	15	125.5	±12	0	±208	83	±47
VK-4815D5	18-72	15	125.5	±15	0	±166	83	±47
VK-4818D5	18-72	15	130.2	±18	0	±138	80	±22
VK-4824D5	18-72	15	130.2	±24	0	±104	80	±22

Suffix "H" means 3.5KVdc isolation

Suffix "P" means Plastic case instead of standard Metal Case

NOTE

1. Ripple/Noise measured with a 1uF ceramic capacitor.
2. Test by nominal input voltage and constant resistor load.
3. Measured Input reflected ripple current with a simulated source inductance of 12uH.
4. It's recommended to add (C1, C2, L) in input end to achieve EN55032 conducted Class A.
5. An external filter capacitor is required if the module has to meet IEC61000-4-5.
The filter capacitor Motien suggest: Nippon - chemi - con KY series, 220uF/100V.
6. Exceeding the absolute ratings of the unit could cause damage. It is not allowed for continuous operating.

TEST CONFIGURATIONS

Output Ripple & Noise Measurement Test

Use a capacitor Cout(1.0uF) measurement.
The Scope measurement bandwidth is 0-20MHz.

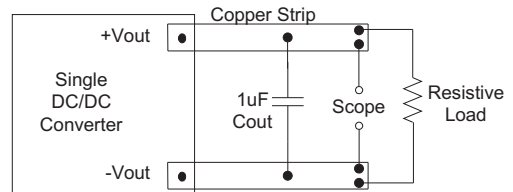

Input Reflected Ripple Current Test Step

Input reflected ripple current is measured through a source inductor Lin(12uH) and a source capacitor Cin(47uF, ESR<1.0Ω at 100KHz) at nominal input and full load.

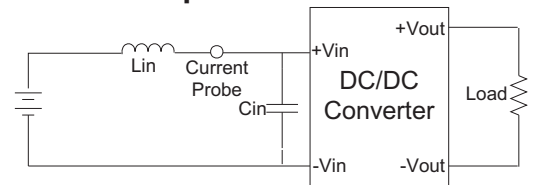

EMI Filter

Input filter components (C1,C2, L) are used to help meet conducted emissions requirement for the module. These components should be mounted as close as possible to the module; and all leads should be minimized to decrease radiated noise.

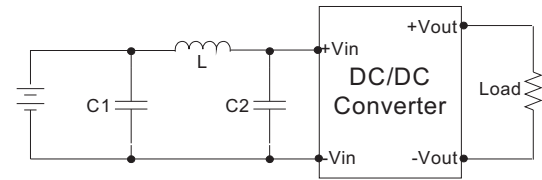

C1	L	C2
68uF, 100V	12uH	33uF, 100V

ELECTRICAL CHARACTERISTIC CURVES

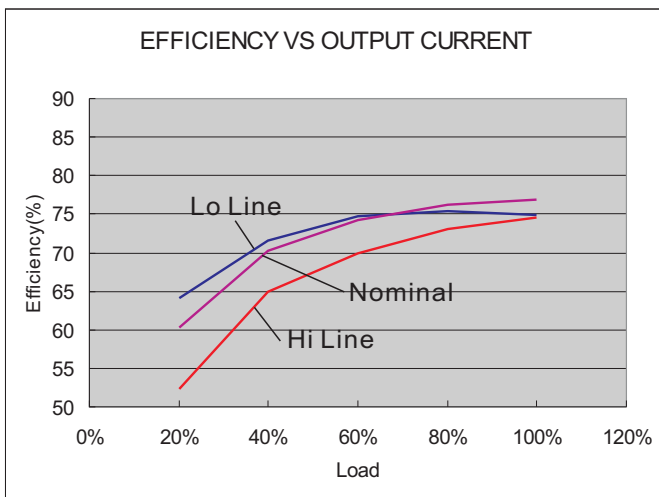

24 Models

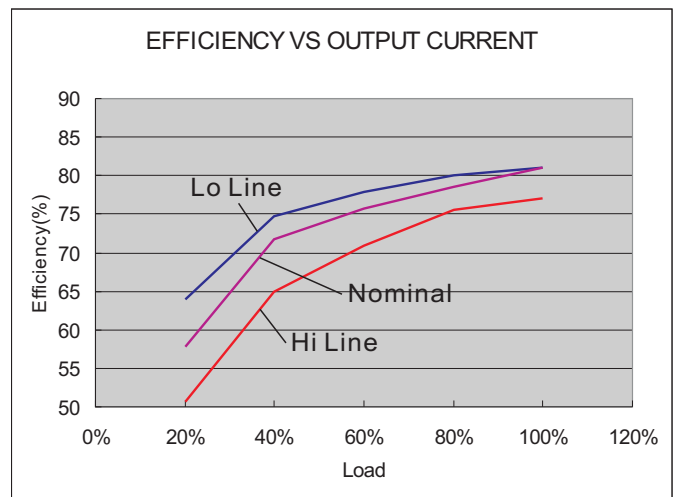

48 Models

The models listed above is just for standard type. If you need the special specification product, please contact our service member by telephone presented in shortform cover or e-mail to : sales@motien.com.tw

MECHANICAL SPECIFICATIONS

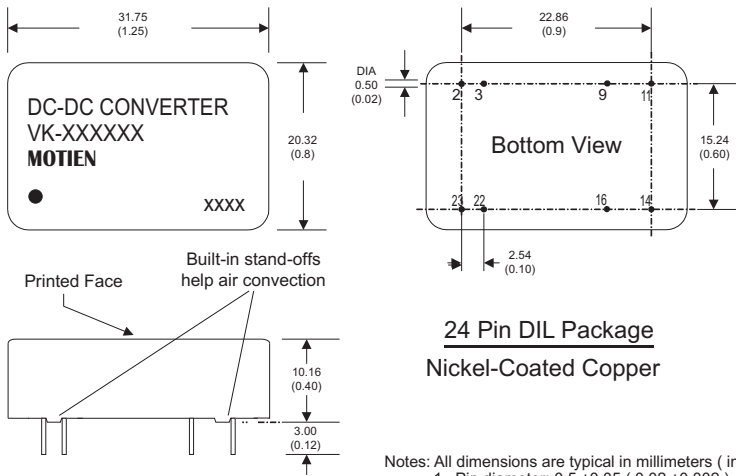

**24 Pin DIL Package
Nickel-Coated Copper**

Notes: All dimensions are typical in millimeters (inches).
 1. Pin diameter: 0.5 ± 0.05 (0.02 ± 0.002)
 2. Pin pitch and length tolerance: ± 0.35 (± 0.014)
 3. Case Tolerance: ± 0.5 (± 0.02)

PIN CONNECTIONS		
PIN NUMBER	SINGLE	DUAL
2	-V Input	-V Input
3	-V Input	-V Input
9	N.P.	Common
11	N.C.	-V Output
14	+V Output	+V Output
16	-V Output	Common
22	+V Input	+V Input
23	+V Input	+V Input

(The Pin Connection of high isolation one is the same with normal one.)

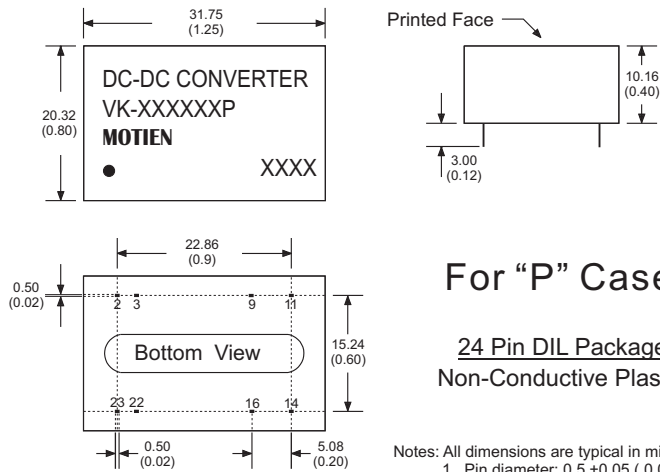

**For "P" Case
24 Pin DIL Package
Non-Conductive Plastic**

Notes: All dimensions are typical in millimeters (inches).
 1. Pin diameter: 0.5 ± 0.05 (0.02 ± 0.002)
 2. Pin pitch and length tolerance: ± 0.35 (± 0.014)
 3. Case Tolerance: ± 0.5 (± 0.02)

PIN CONNECTIONS		
PIN NUMBER	SINGLE	DUAL
2	-V Input	-V Input
3	-V Input	-V Input
9	N.P.	Common
11	N.C.	-V Output
14	+V Output	+V Output
16	-V Output	Common
22	+V Input	+V Input
23	+V Input	+V Input

(The Pin Connection of high isolation one is the same with normal one.)